

SERVICE MANUAL

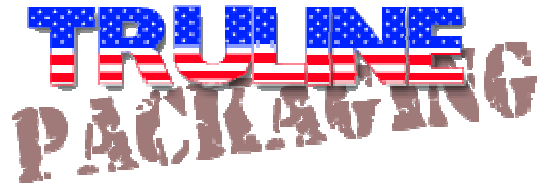

Model TL1622MK-COMBO



**8822 Flower Road #120
Rancho Cucamonga, CA 91730
PHONE (909) 945-2940
FAX (909) 945-2939**

INSTRUCTIONS FOR OPERATION AND REPAIR OF THE
TRULINE PACK TL1622MK-COMBO

TL1622MK-Combo Service Manual

IMPORTANT - PLEASE READ THIS CAREFULLY

The development of a good safety program, that is rigidly enforced, is absolutely imperative when involved in the operation of industrial equipment. Our machinery is well designed and includes extremely important safety features. The part you the user play through proper installation and maintenance procedures is of far greater significance than our designs. Only properly trained individuals following rigidly enforced safety rules, as recommended by A.N.S.I. and O.S.H.A., should be allowed to operate these machines.

TL1622MK-Combo Service Manual

TABLE OF CONTENTS

Preface

Unpacking	5-9
Warranty Notice	10
Warranty	11-12
Warranty Exceptions	13
Warnings	14-16

Description and Specifications	17
Installation and Basic Set-Up	18-26
Film Threading Diagram	27
Sequence of Operation	28-31

Tunnel Section

Front Panel Diagram	32
Sequence of Operation	33-35
Temperature Control Adjustment	36

TROUBLESHOOTING 37-64

No Heat to "Micro Knife" Band Ribbon	37-42
Unbalanced Heat from Front and Side	43-44
Weak Seals/Poor Cut Off	45-46
Conveyor Will Not Run	47-49
Magnetic Hold Down	50-52
Excessive Film Drag	53
Excessive Film Winding	54
Conveyor Malfunction	55-58
No Air Flow	58-60
No Heat	61-63

MAINTENANCE 64-90

Sealer Section	64
Micro Knife Band Ribbon Adjustment	64-66
Micro Knife Band Ribbon Replacement	67-72

TL1622MK-Combo Service Manual

Tape Replacement	73
Sealing Pad Replacement	74
Sealing Pad Pressure Adjustment	75
Adjust Height of Seal Bar	76
Pulse Switch Adjustment	77
Adjust Magnet Seal Pressure	78
Conveyor	79
Conveyor Motor Replacement	80
Replacing Seal Bars	81-84
Installing Transite Channels	85-86
Installation of Band Ribbon Compensator	87-89
MAINTENANCE	90-105
Tunnel Section	90
Replacing Conveyor Rollers	91-93
Replacing Idler Shaft	94
Replacing Drive Shaft	95
Replacing Conveyor Motor	96
Replacing Heater Bank	97-98
Temperature Controller Replacement	99
Blower Motor Replacement	100-102
Wear Rails Lower Adjustment and Replacement	103-104
Wear Rails Upper Adjustment and Replacement	104-105
Electrical Panel Diagram-Tunnel	106
Electrical Panel Diagram-Sealer	107
Electrical Schematic-Tunnel Section	108
Electrical Schematic-Sealer Section	109
Parts Nomenclature-Tunnel	110
Replacement Parts List-Tunnel	111-113
Parts Nomenclature-Sealer	114
Replacement Parts List-Sealer	115-118
Spare Parts List	119

TL1622MK-Combo Service Manual

UNPACKING**THOROUGHLY INSPECT EQUIPMENT UPON ARRIVAL.**

If goods are received short or in a damaged condition, it is important that you notify the carrier's driver **before he leaves your company** and **insist** on a notation of the loss or damage across the face of the freight bill. Unless this is done, no claim can be enforced against the transportation company.

If concealed loss or damage is discovered, notify the carrier at once and **insist** on an inspection. This is absolutely necessary! A concealed damage report must be made no later than ten (10) days from the date the shipment was delivered. Unless you do this, the carrier will not consider any claim for loss or damage. The carrier's agent will then make an inspection and grant a concealed damage notation. If you give the transportation company a clear receipt for the goods that have been damaged or lost in transit, you do so at your own risk and expense.

All claims must be filed within 30 days of delivery date or carrier will not accept them.

TRULINE Packaging is willing to assist in every possible manner to collect claims for loss or damage; however, this does not hold TRULINE Packaging responsible for collection on claims or replacement of material.

TL1622MK-Combo Service Manual

Your new TRULINE Pack Model TL1622MK-COMBO comes bolted to a pallet and has a tri-walled corrugated box strapped to the pallet to protect it.



1. If your machine does not arrive in this condition, **write on shipping paperwork that outside of box is damaged. Concealed damage may have occurred.**



2. Remove stretch film and Poly Bag covering machine.

TL1622MK-Combo Service Manual



3. Remove film rack from under L'Sealer.

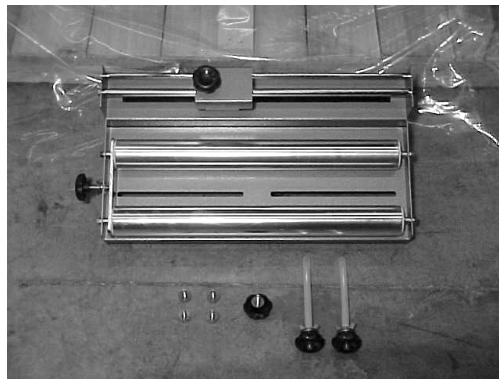

4. Check film rack. You should have
 - (a) Film Rack
 - (b) (4) mounting bolts
 - (c) (1) adjustable knob
 - (d) (2) film roll guides

TL1622MK-Combo Service Manual



5. Install crank handle on tunnel hood using the two Allen bolts provided.



6. Mount film rack roll guides as shown.



7. Remove bolts holding machine to pallet using 13-mm wrench.

TL1622MK-Combo Service Manual

8. Place forks of forklift under center of lower support bar of frame and lift off pallet.
9. Place in desired location and use locking casters to set in place.

IMPORTANT WARRANTY NOTICES

OPERATING AND MAINTENANCE MANUAL

The operating and maintenance manual has been carefully prepared to provide the user with all the information needed to properly install, operate, and maintain your TRULINE Packaging equipment.

Please read this manual carefully and refer to it for information on the care and use of your TRULINE Packaging equipment. It is recommended that additional copies be ordered for use by production, maintenance, and supervisory personnel. Although the design of this equipment incorporates safeguards to protect personnel, care should be used in operating, adjusting, and servicing.

Attention is directed to the warranty that accompanies all your TRULINE Packaging equipment. The terms and conditions of this warranty apply only to unmodified units. **Any unauthorized modifications to the equipment automatically voids this warranty.**

TRULINE PACKAGING

WARRANTY

EFFECTIVE 1-1-99

TRULINE Packaging, Inc. warrants each new product manufactured to be free from defects in material and workmanship for a period of (1) year from date of shipment by TRULINE Packaging.

This warranty is not transferable with any subsequent resale.

Defective parts under warranty must be returned to TRULINE Packaging freight prepaid. TRULINE's sole obligation and purchaser's sole remedy in the event of a warranty dispute shall be, at TRULINE's option , to repair or replace the part in question. Labor incurred in removing or installing the defective part is not covered by this warranty. Prior to returning any parts for any reason, contact TRULINE Packaging for a Return Authorization Number. This number must accompany all returns.

This warranty shall not apply if equipment has been tampered with, misused, improperly installed, altered, or has received damage due to abuse, carelessness, accident or failure to follow recommended regular maintenance procedures or has been serviced by someone other than a duly authorized factory representative without the express written consent of TRULINE Packaging, Inc.

TL1622MK-Combo Service Manual

This warranty is in lieu of all other warranties, expressed or implied, including but not limited to warranties of merchantability and fitness for a particular purpose, non-infringement or any other matter.

TRULINE Packaging shall have no liability to any person for direct, indirect, incidental or consequential damages or delay resulting from any defect negligence, or tort and customer hereby waives for itself any and all claims for punitive damages and all claims of negligence of strict liability or both. In no event shall our liability exceed the purchase price of the product that was actually paid.

TRULINE Packaging reserves the right to make changes, additions, or improvements to our products with no obligation to make such changes in any previously shipped product covered by this warranty.

TRULINE Packaging shall not be held liable for any damages arising out of nor in connection with the operation of the equipment should customer or its agent fail to maintain equipment in safe operating condition. This warranty shall become unenforceable if and to the extent the customer or its agents remove, disconnect, or otherwise render useless any safety device and or parts designed or affixed by us or fails to maintain and service equipment in a manner as advised.

TRULINE Packaging provides a one-year warranty on parts, excluding shipping or freight costs for replacement parts. All warranty parts are shipped F.O.B. Rancho Cucamonga, California. Service Labor to install part is not covered under warranty

TL1622MK-Combo Service Manual

WARRANTY EXCEPTIONS

The following parts are an exception to the general warranty list on page 10. Each part listed below shall carry a 30-day warranty unless designated otherwise.

TL1622MK-COMBO Parts

1. Conveyor Belt
2. Fuses

The following sealer parts are considered to be consumable and not under warranty:

1. Silicone Sponge
2. Teflon Tapes
3. Nylon Sleeves

WARNINGS

Every effort has been taken to ensure your safety while operating this machine; however, there still remain certain risks. Do not allow this machine to be operated before informing all personnel of the following warnings.

WARNING.....

Do not tamper with the electrical wiring. Only use a licensed electrician for maintenance. Always disconnect the electrical power before attempting any maintenance to all electrical and/or moving parts.

WARNING.....

In order to prevent injury to personnel and/or machinery DO NOT INCREASE SETTINGS OR RATINGS ON EITHER ELECTRICAL OR MECHANICAL OVERLOAD SAFETY DEVICES.

WARNING.....

KEEP HANDS AWAY FROM MOVING CONVEYORS AND ASSEMBLIES. Conveyor belts that have become worn or frayed are capable of being hazardous. They should be replaced promptly.

WARNING.....

NEVER OPERATE THIS OR ANY MOVING EQUIPMENT WITHOUT ALL COVERS AND GUARDS IN PLACE. The internal mechanism of most packaging machinery contains numerous shear,

TL1622MK-Combo Service Manual

pinch, and inrunning nip points, many of which are capable of causing severe injury and/or permanent disfigurement.

WARNING.....

To minimize the potential for personnel injury, always be sure that machine operators and others working on the machinery are properly trained in the correct usage of the equipment and properly instructed regarding the safety procedures for operation.

WARNING.....

Heat sealing arms and sealing jaws on packaging machinery can become very warm after a period of use. KEEP HANDS AWAY WHILE IN OPERATION AND USE CAUTION IF THE MACHINE HAS BEEN RUNNING RECENTLY.

WARNING.....

ANY MODIFICATIONS TO EITHER THE ELECTRICAL CIRCUITRY OR THE MECHANICAL ASSEMBLIES OF THE MACHINERY WILL VOID ANY WARRANTIES ASSOCIATED WITH THIS EQUIPMENT. Such modifications may introduce hazards that would not otherwise be associated with this machinery. TRULINE Packaging will not be responsible for any consequences resulting from such unauthorized modifications.

WARNING.....

The use of certain types of plastic films in sealing and/or shrinking equipment may result in the release of HAZARDOUS FUMES due to the degradation of the film at high temperatures. Before using any plastic film in this equipment, the manufacturer or supplier of the film should be contacted for specific information concerning

TL1622MK-Combo Service Manual

the potential release of hazardous fumes. ADEQUATE VENTILATION MUST BE PROVIDED AT ALL TIMES.

WARNING.....

It is important that the machine operator turn off the Main Power Switch when he/she has finished operating the unit.

TL1622MK-Combo Service Manual

**DESCRIPTION AND SPECIFICATIONS OF
TRULINE PACK MODEL TL 1622MK-COMBO****DESCRIPTION**

The purpose of a TL1622MK-COMBO is for medium to high volume packaging requiring excellent seals and minimal maintenance. It features "micro knife technology" for sealing of films. This model incorporates an electromagnetic hold-down system, allowing the operator to load another package while the preceding package is being sealed. In addition, a package take-away conveyor increases production speed by automatically discharging product into the tunnel.

SPECIFICATIONS

Model:	TL 1622MK-COMBO
Seal Area:	Width: 16" Length: 22"
Machine Size:	Length: 103" Width: 32" Height: 62"
Volts:	220
Phase:	1
Amperage:	45
Weight:	800 lbs.

TL1622MK-Combo Service Manual

INSTALLATION AND BASIC SET-UP**IMPORTANT**

Read this manual carefully, and make it available to everyone connected with the supervision, maintenance, or production of this machine. Additional copies are available at your request. (Contact your distributor for this information.) Be very careful when operating, adjusting, or servicing this equipment. If in doubt, stop and obtain qualified help before proceeding.

INSTALLATION OF TL1622MK-COMBO

Place the machine in the desired location with the required electrical power source available. (See power requirements.) Make certain that proper electrical wiring is provided to guard against low voltage. If the voltage is too low, the equipment will not function properly.

Finding the proper location is a most important function of the initial set-up. One must take several factors into consideration:

1. Adequate power source.
2. Relationship to source of product.
3. Relationship to machine.
4. Relationship to any conveyors necessary to remove finished product.
5. Convenience of operator.

An electrician should install a plug on the end of the main power cord. If there is any doubt, get qualified assistance to do the initial installation. **Do not take any chances!**

TL1622MK-Combo Service Manual

Do not attempt to install, adjust, or operate this machine without first reading the contents of this manual. Although the design of the equipment incorporates safeguards to protect operating and maintenance personnel, care should be used in operating, adjusting, and servicing.

INSTALLING FILM RACK

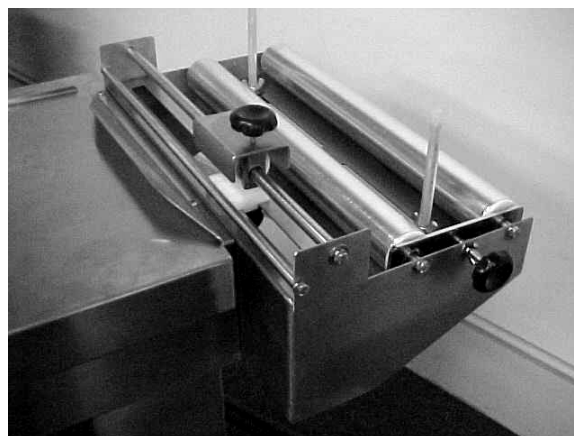

IMPORTANT: Remove film rack from under machine and install at the end of the sealer on the right hand side with the

TL1622MK-Combo Service Manual

four bolts and center knob provided. Mounting holes are slotted for adjustment, set film rack flush with backside of the machine frame.

TL1622MK-Combo Service Manual

MOUNTING FILM

Select the proper width of centerfold film for the item being packaged, allowing for width and height of package. With the package properly positioned within the film in the sealing area, allow sufficient film to overlap the sealing bars so that a seal may readily be made without any possibility of open areas due to insufficient film.



Place film roll on cradle mount film rack. The centerfold is to be placed away from the operator, toward the rear of the machine. Position film roll on rack and tighten film guide nuts to hold film roll in position.

Thread film through the Pin Perforator. Note that the perforator wheel turns freely and is not binding.

TL1622MK-Combo Service Manual



Once threaded, separate film top from bottom and insert product tray between. Make sure that the centerfold of film is placed at the rear of the product tray. This allows the operator to insert product between the layers of film on the product tray and to prepare to move product and film into the sealing area. When threading film, make sure to pull more than sufficient film through the rollers, across the product tray, and into the sealing area to ensure sufficient film to begin operation.

Place product against rear of film separator tray. Then move product into seal area. Be sure to leave the bag loose around the product when making the seal. This helps eliminate the seals from blowing out in the shrink tunnel. This completes threading and/or mounting film.

PIN PERFORATOR

TL1622MK-Combo Service Manual



Located between the lower idler rollers, the pin perforator creates holes for air escape as the operator pulls on the film. This allows the air to escape as the package travels through the tunnel.

The pin perforator is adjustable and must be properly placed in conjunction with the width of the desired package. The positioning should always be re-evaluated when setting the machine for different size product or different size film. Adjustments may be made with the adjustment knob attached to the bottom of the film rack.

FILM BRAKE

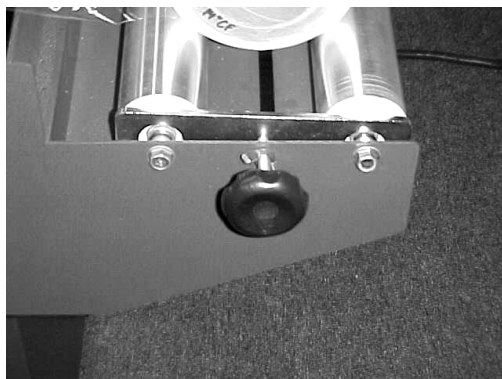

The film brake is located on the operator side of the film cradle. It serves to create tension on the dispensing film, in order to prevent

TL1622MK-Combo Service Manual

over-run and/or slack. From time to time, the operator should re-evaluate its setting to ensure proper tension.

PRODUCT TRAY



The product tray is an adjustable metal platform used to separate film and to insert product between top and bottom layers of film.

The tray is adjustable to achieve proper depth, equal to the depth of the package, allowing product to be placed exactly in the centerfold of the film each time. A locking wing screw allows you to set tray position.

LOCKING WING SCREW

TL1622MK-Combo Service Manual



Once the product is placed in the desired location, tighten the wing screw under the loading tray to lock tray in position.

Power Discharge Conveyor



Lower Power Discharge Conveyor using the crank wheel located underneath the Power Discharge Conveyor. The Conveyor should be set so the package height is centered to the seal pad. In essence, $\frac{1}{2}$ of the package is above the seal pad and the other $\frac{1}{2}$ of the package is below the seal pad. This will place the seal in the center of your package and help release any film tension that may occur.

TL1622MK-Combo Service Manual



Loosen knob under L'Sealer, this will allow you to move L'Sealer portion of machine to center product transferring from powered conveyor into tunnel.



Move L'Sealer portion of machine forward or backward depending on your product size. This will allow your product to transfer from L'Sealer into the center of the tunnel giving you optimum shrink quality. Tighten knob when set.

TL1622MK-Combo Service Manual



Adjust crank handle on tunnel to move tunnel up or down allowing you to center tunnel height with the height of the discharge conveyor on sealer.



Always try to set tunnel height the same as L'Sealer discharge conveyor height for smooth product transfer.

TL1622MK-Combo Service Manual

COMPENSATOR ADJUSTMENT

Because of the importance of the adjustment of the Band Ribbon compensator to the successful operation of the sealer, the following explanation of its operation is given.

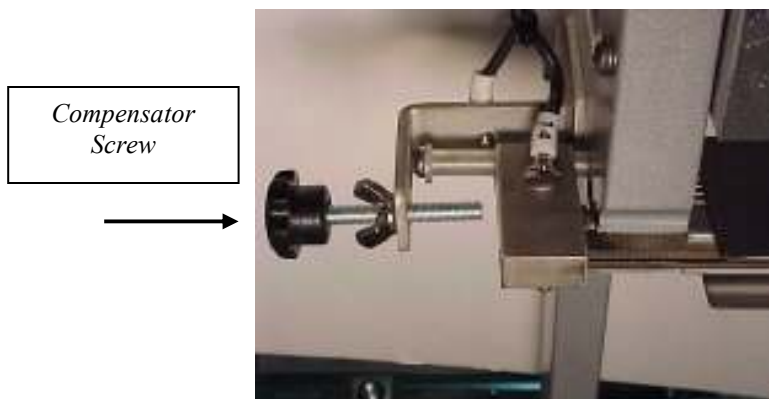

The front stainless steel compensator is used to adjust the Band Ribbon temperature. As the seal head is lowered against the bottom seal pad, a pulse switch is activated at the rear of the seal bar supplying voltage to heat the Band Ribbon. As the Band Ribbon heats up, the stainless steel compensator is spring-loaded and expands as the Band continues to heat. When the compensator finally expands to the point that it touches the threaded screw, the circuit is completed and the supply voltage is turned off. The simple principle of this device is to compensate for the residual heat that builds up in the Band Ribbon. As you operate the L'Sealer faster and faster, the actual amount of heat from the Band Ribbon stays constant, reducing the amount of heat transferred to the teflon tape or seal sponge.

NOTE: The farther away you set the threaded compensator screw from the compensator, the hotter the Band Ribbon will become. A

TL1622MK-Combo Service Manual

good starting point is to allow a gap of ¼". Thicker film such as 100GA Polyolefilm might require a slightly larger gap.

FILM THREADING DIAGRAM

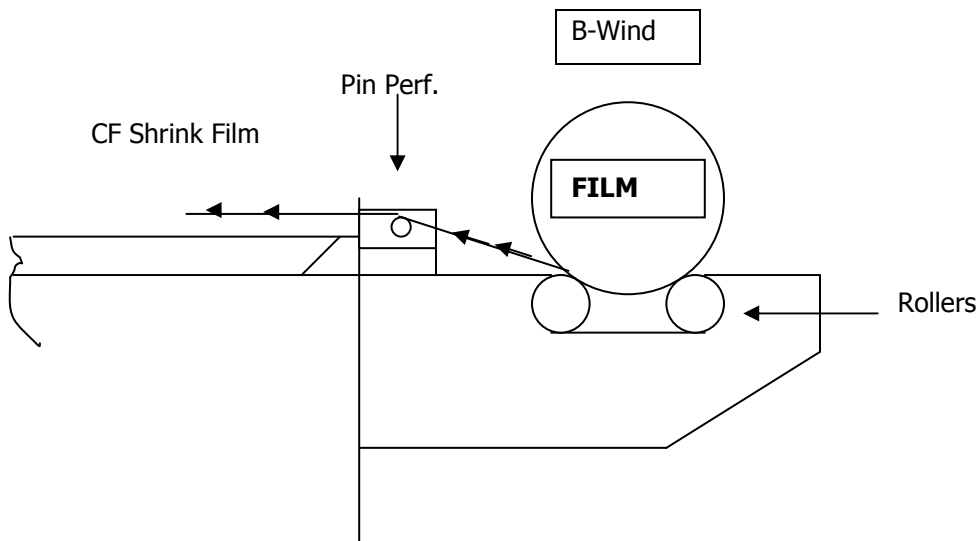

TL1622MK-Combo Service Manual

SEQUENCE OF OPERATION

- A. Turn on main power switch on backside of shrink tunnel, then turn on power switch to L'Sealer located under product loading tray.
- B. Product is placed on the product-loading tray.
- C. The product tray functions as a means to separate the film, allowing placement of product between upper and lower portions of the film.
- D. Move product into seal head area by pushing the product to the left.
- E. As the seal head is lowered toward the bottom seal pad, the cycle switch is activated which initiates the "micro knife" Band Ribbon, magnet time and conveyor time. The timers are located in the front of the machine and can be adjusted from 0 to 6 seconds.
- F. Take-away Conveyor Unit - Once the seal is completed, the seal head automatically releases and the take-away conveyor begins to run. It is adjustable from one(1) to six (6) seconds. The timer is located on the front of the machine.

NOTE: If too much tension is on the film while the bag is being made, the seals will, more than likely, be weak or will "blow out" in the seal area while passing through the shrink tunnel. Make sure to relax the film tension prior to sealing.

- G. Adjust discharge conveyor timer long enough to move product from L'Sealer into shrink tunnel.

TL1622MK-Combo Service Manual

SEQUENCE OF OPERATION

1. After setting the Band Ribbon compensator for the film type in use (see page 27 for instructions), proceed as follows:



- A. With film threaded, (see instructions for mounting film) place right hand on package and slide product into the upper left hand corner of the film (i.e. corner formed by folded rear edge of film and previously sealed left edge of film), pushing the package up against the 1/2" high package stop at rear of product loading tray.

TL1622MK-Combo Service Manual



- B. Place **right hand** under top sheet of film and on front right corner of product. Place **left hand** on tail of both sheets of film. Now push the package with right hand and pull the film with left hand moving package and film into lower right corner of seal area. Allow from ½" to 1" of extra film around package. This will allow some slack film between the package and the sealing bars, reducing film tension.



- C. Press sealing handle down. **IMMEDIATELY** release pressure. The sealing head will remain down for the duration of the time set on the seal timer.

TL1622MK-Combo Service Manual



- D. The operator may then load the next package onto the product tray, thus speeding up the sealing operation.



- E. Power discharge conveyor will discharge package into shrink tunnel.

The next section will explain your tunnel functions and controls.

TRULINE PACK -- Front Panel Diagram

APPLICABLE FOR ALL PP TUNNELS

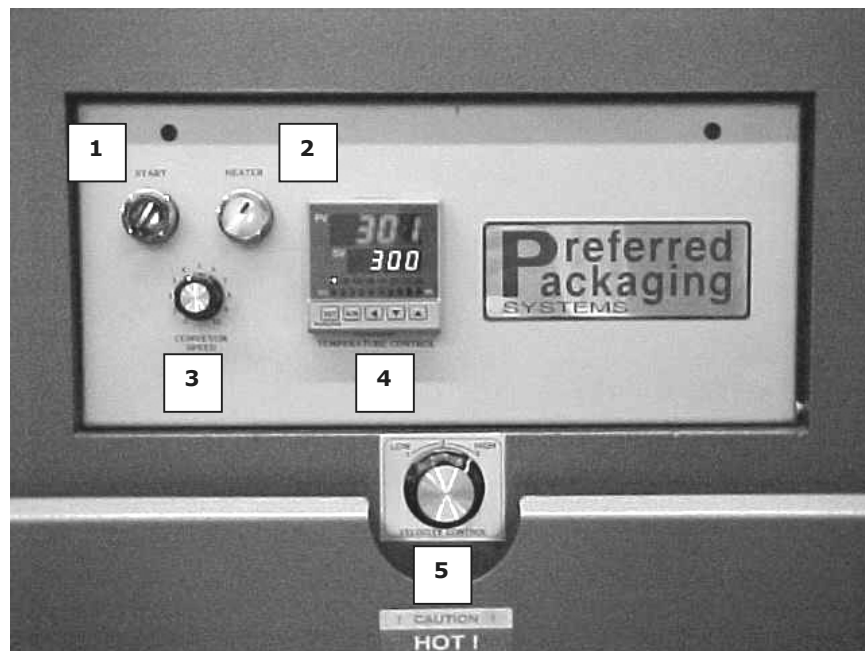

1. Start Switch -- Green
2. Heater Switch -- White
3. Conveyor Speed Control – Small Black Knob
4. Digital Temperature Control
5. Air Velocity Control – Large Black Knob

TL1622MK-COMBO Service Manual

SEQUENCE OF OPERATION



- A. Turn the tunnel on by flipping the main breaker switch to the **ON** position at rear of the machine.

TL1622MK-COMBO Service Manual

SEQUENCE OF OPERATION

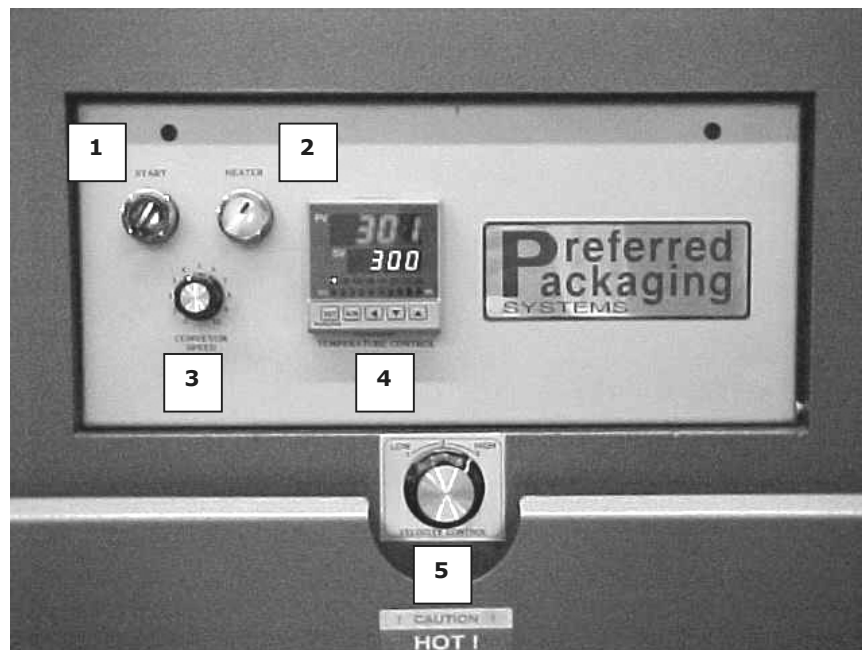

- A. **Turn the START switch** (1) to the on position to start the machine. (Temperature will be displayed on temperature control at this time. This will also start the cooling fan motor.)
- B. **Turn the HEATER switch** (2) the on position, this will start the blower, conveyor motors and heater.
- C. **Set the Conveyor Speed Control** (3) to about mid-range until the exact desired conveyor speed is determined later (based on package size and sealer speed). Factory setting is 4.
- D. **Set the Temperature Controller** (4) at the temperature you believe will shrink your product. This temperature may need to be adjusted higher or lower until you have achieved the shrink you are happy with for that product. As long as you are

TL1622MK-COMBO Service Manual

running the same product, this temperature should not have to be adjusted again. Factory setting is 290 degrees.

SEQUENCE OF OPERATION

- E. **Turn Air Velocity Control knob** (5) to high. Most tunnel applications will use high air velocity. You may lower the Air Velocity for (a) lightweight packages that may lift or float from excess air pressure or (b) should you want to decrease the shrink force of the film. Factory setting is high.

- F. **CAUTION: When turning off the tunnel, be sure to turn off by means of the heater bank switch. The tunnel will automatically shut off at about 180 degrees.**
(Temperature will be displayed on temperature controller at this time.) Turn off the start switch and then the main breaker located in the back of the tunnel.

TL1622MK-COMBO Service Manual

Temperature Control Adjustment

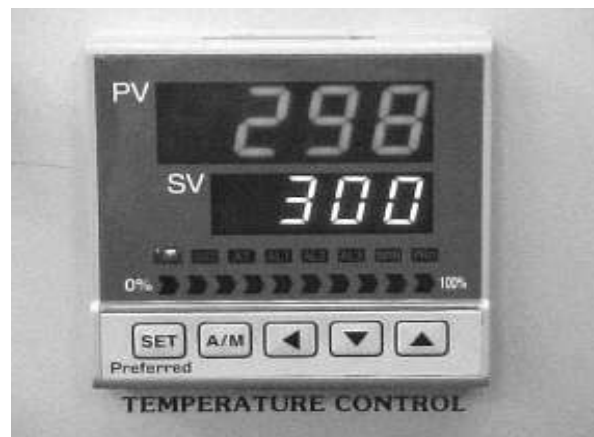

PV = Present Value

SV = Set Value

On the above temperature controller the set value is 300 degrees and its present temperature is at 298 degrees.

To Adjust Temperature Up or Down:

First you must press the arrow key that points left (←). When pressing this key the set value temperature will flash first in the ones column. While flashing, you may adjust temperature by now pressing the arrow keys either up or down (↑↓) to the desired temperature in the ones column. Repeat this procedure by pressing the left arrow (←) to move flashing light to the tens column or the hundreds column and adjust up or down to desired temperature.

TL1622MK-COMBO Service Manual

Once you have adjusted to desired temperature press the set key and the temperature will now become your new set value (SV).

TL1622MK-COMBO Service Manual

TROUBLESHOOTING – L'SEALER PORTION

The following guidelines are provided to aid in determining the source of any operation difficulties which may develop. In performing the tests and checks which follow, carefully inspect for any loose components, broken or loose wires, poor electrical connections, etc., while testing the various switches, controls, relays, transformers, etc. For checking electrical problems, use a voltage meter.

Note: While troubleshooting use caution to avoid danger of electrical shock. When power is not required for checking for the presence or value of voltages used, always have it disconnected.

DISCONNECT ALL POWER BEFORE MAKING ANY REPAIRS.

REFER TO ELECTRICAL BOARD LAYOUT AND ELECTRICAL SCHEMATIC FOR LOCATION OF ELECTRICAL COMPONENTS

NO HEAT TO BAND RIBBON



1. Check that the sealer is plugged in and that power is present at the socket. Make sure the power switch is in the **ON** position.

TL1622MK-COMBO Service Manual

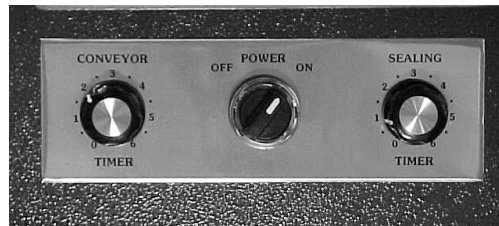

2. Make sure timer is **not** set on zero (0) on time dial.

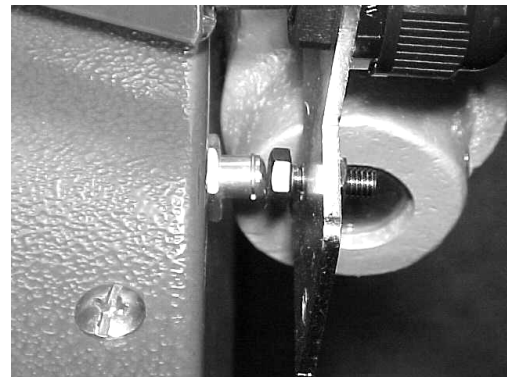
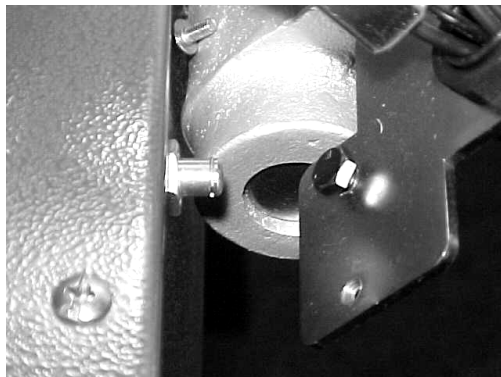

3. **Check micro knife pulse switch adjustment.**
 - (a) Make sure switch is being activated when the seal bar is within $\frac{1}{4}$ " of contact with seal pad.
 - (b) Press switch by hand. If no click is heard, replace switch.

TL1622MK-COMBO Service Manual

F6 – 2 AMP

F5 – 3 AMP

F4 – 2 AMP

F3 – 15 AMP

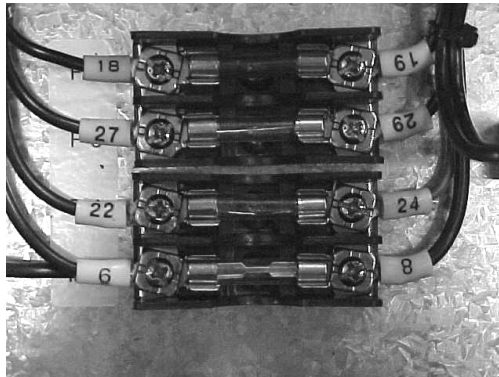

F1 – L1 --15AMP

F2 – L2 -- 15 AMP



4. Check all fuses.

TL1622MK-COMBO Service Manual

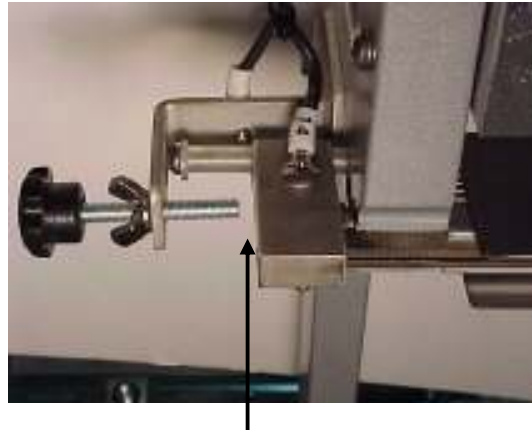

GAP 1/8" to 1/4"

5. Check micro knife compensator setting. You should always have a gap of at least 1/8" to 1/4" between the compensator and the adjustment screw. If the compensator screw is touching the compensator the micro knife will not heat up.

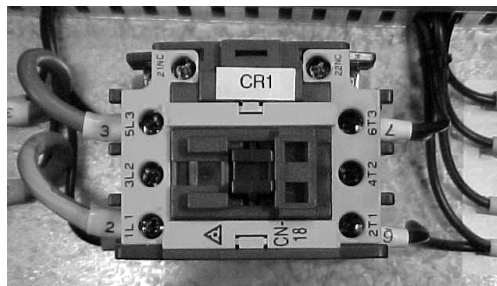

6. Check to see if CR1 contactor is pulled in at all times when Main Switch is in the ON position.

TL1622MK-COMBO Service Manual

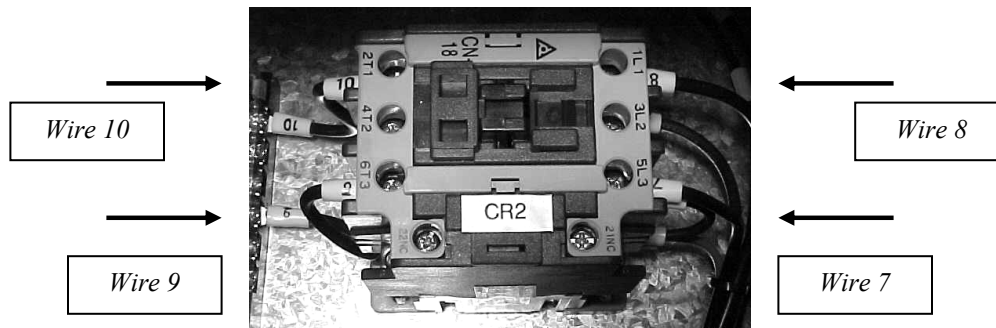

7. Check for operation of contactor – CR2.
 - (a) Check for 220 power on wires 7 and 8. When CR2 is pulled in, you should have 220 present on wires 9 and 10.
 - (b) Manually engage contactor and check for continuity on each leg. If required, clean or replace contact points or replace contactor.

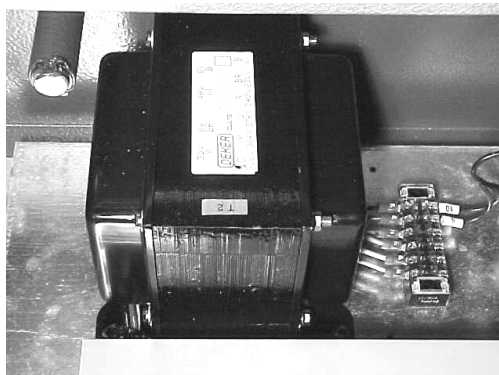

8. Check for voltage present at both primary and secondary of transformer T2 as per values shown in the voltage specifications.

TL1622MK-COMBO Service Manual



9. Check for broken band ribbon inside or outside the corner block.

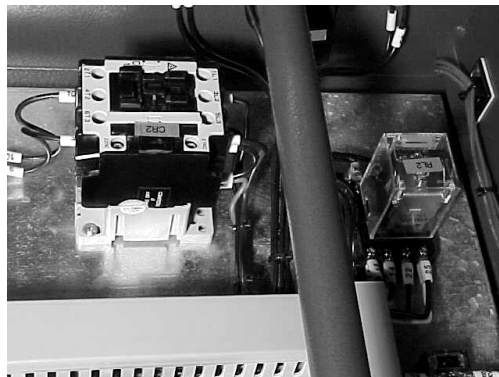

← RL2

10. Check RL2 relay to make sure it is secure in the socket.

TL1622MK-COMBO Service Manual

UNBALANCED HEAT FROM FRONT AND SIDE MICRO KNIFE BAND RIBBON



1. Check corner block, make sure teflon insulation piece covering micro knife band ribbon described on page 70 is securely in place. **If teflon insulation is missing or worn out the band ribbon will ground against corner block not allowing heat to transfer in the corner.**

TL1622MK-COMBO Service Manual

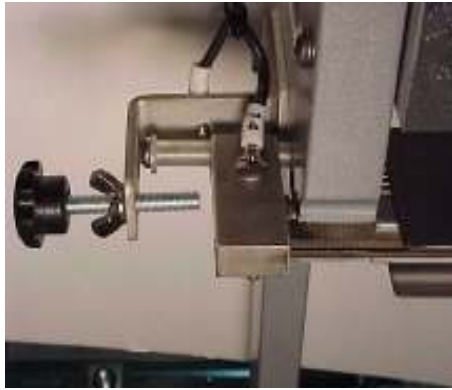

Check Wires 14 and 26



Check Wires 12 and 13



2. Check for poor connection in corner block.

TL1622MK-COMBO Service Manual

WEAK SEALS AND/OR POOR FILM CUT-OFF



1. Improper setting of micro knife compensator. Refer to page 26 for proper adjustment.



2. Improper operating technique. Too much film tension, make sure film is relaxed prior to sealing.
3. Check band ribbon to see if cleaning or replacement is necessary.

TL1622MK-COMBO Service Manual

4. Burned teflon tapes 1/2" or 3/4" replace. If teflon tapes become burned or worn, weak seal may occur. See page 73 for Replacement Instructions.
5. Wavy silicone rubber sealing pad. Replace. (See instructions on page 74.)
6. Seal pad pressure incorrect. (See page 75.)
7. Hold-down pressure uneven or incorrect on magnets. (See page 78 for instructions.)

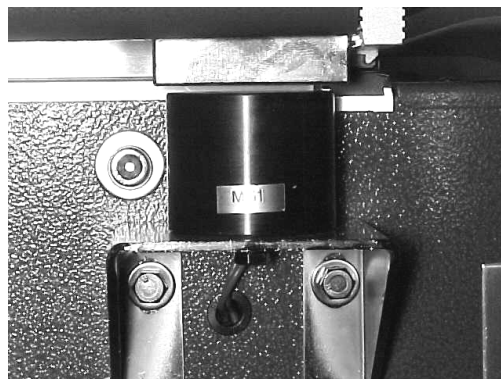

8. When seal bar is lowered, the gap between the lower magnet and the upper magnet clamp should be 1/8".

TL1622MK-COMBO Service Manual

CONVEYOR – WILL NOT RUN

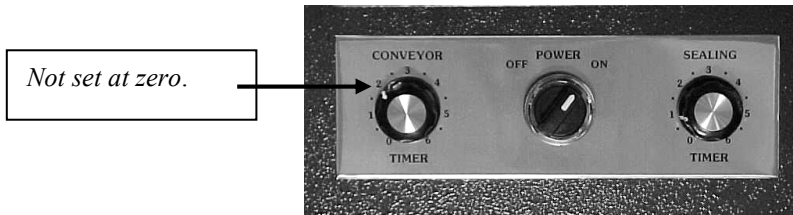

1. Check conveyor timer. Make sure it is **not** set at zero.

F6 – 2 AMP
 F5 – 3 AMP
 F4 – 2 AMP
 F3 – 15 AMP

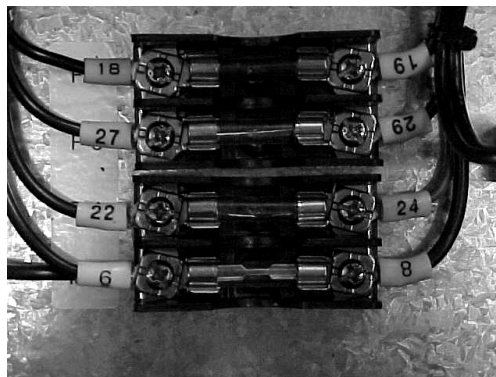

2. Check fuse F-6, 2 AMP, wire 18 and 19.

TL1622MK-COMBO Service Manual

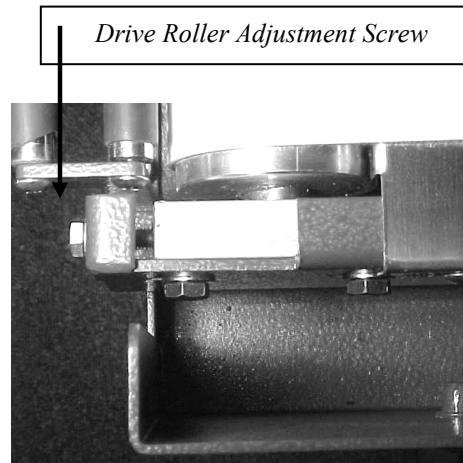

3. **Check conveyor belt** and make sure it is not adjusted too tightly. Adjust conveyor belt using Drive Roller Adjustment Screw.



4. Check that conveyor motor sprocket set screws are not loose on shaft.
5. Check that conveyor chain is not jammed or broken.
6. Make sure wires number 19, 20 and 7 are connected to the conveyor motor.

TL1622MK-COMBO Service Manual

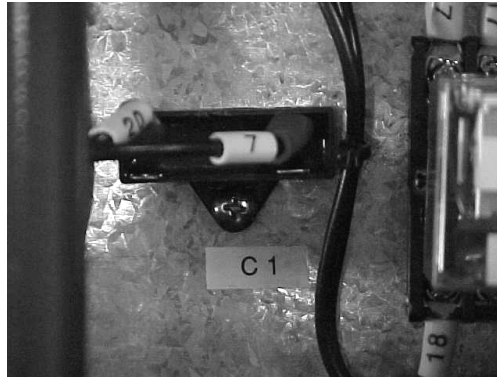

7. Make sure wires number 20 and 7 are connected to C1 capacitor.



8. Make sure RL1, 220V relay is secure in relay socket and points are not burnt.

TL1622MK-COMBO Service Manual

MAGNETIC HOLD DOWN



1. Seal head will not stay down – sealer operates normally otherwise.

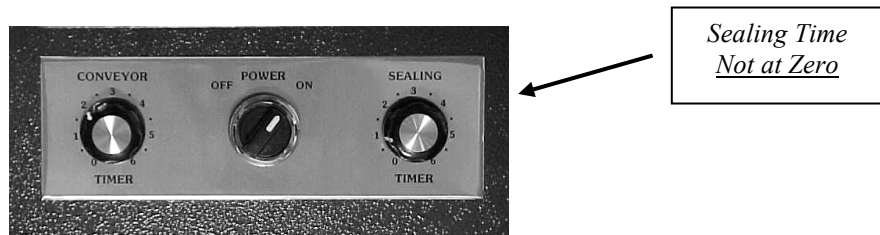

2. Check seal timer (TR2) setting. Make sure it is not set at zero. Also, check to see if burned or damaged.

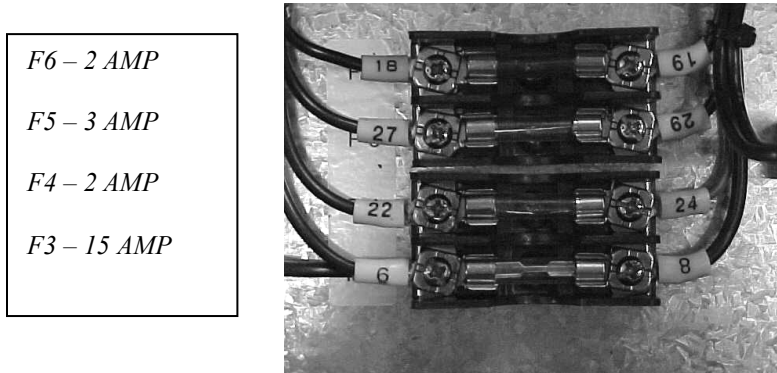

TL1622MK-COMBO Service Manual

3. Check fuse F5, 3AMP, wire 27 and 29.

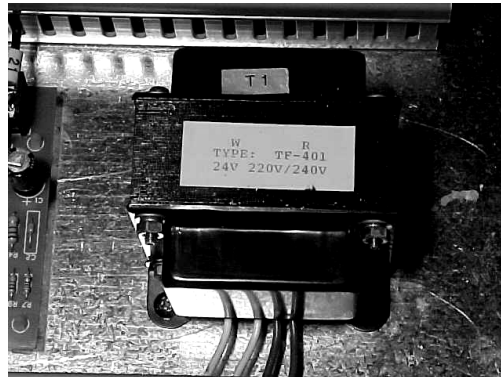

4. Check for 220 Volts (nominal) to primary of transformer (T1).
5. If voltage is present to primary winding of transformer (T1), check for 24 (nominal) volts output from secondary of transformer.

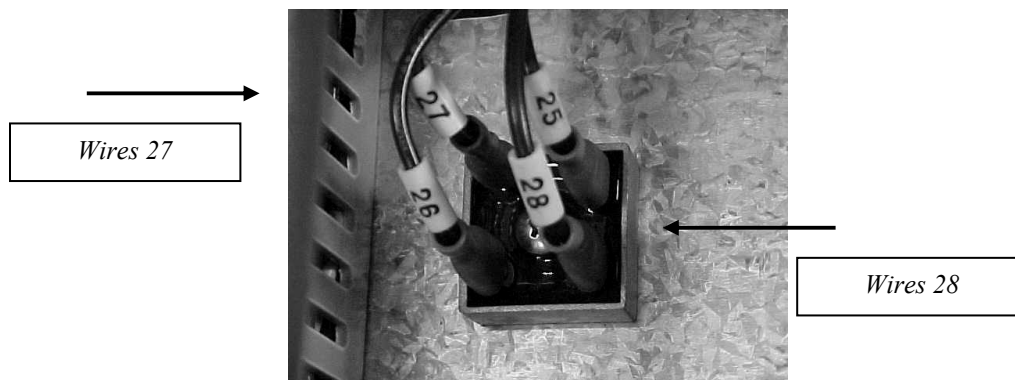

6. Check for 24 (nominal) volts DC output from + (positive) and – (negative) wires number 27 and 28 on terminals of rectifier. If no DC voltage, replace rectifier.

TL1622MK-COMBO Service Manual

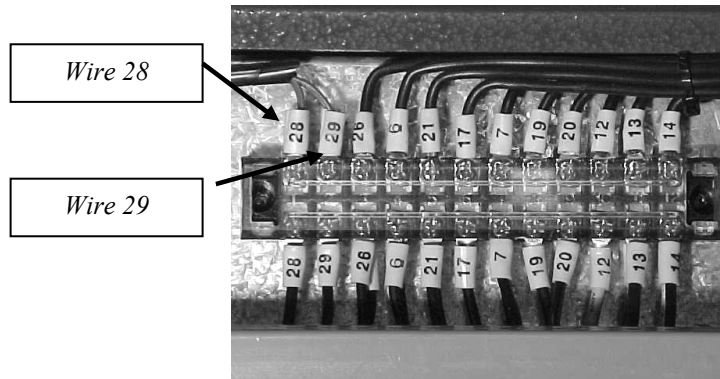

7. Check for circuit continuity through windings of hold-down magnets. **Check on terminal strip wires 28 and 29. Disconnect from terminal strip before testing.**

TL1622MK-COMBO Service Manual

EXCESSIVE FILM DRAG

1. Check for proper film threading. (See diagram on page 23.)

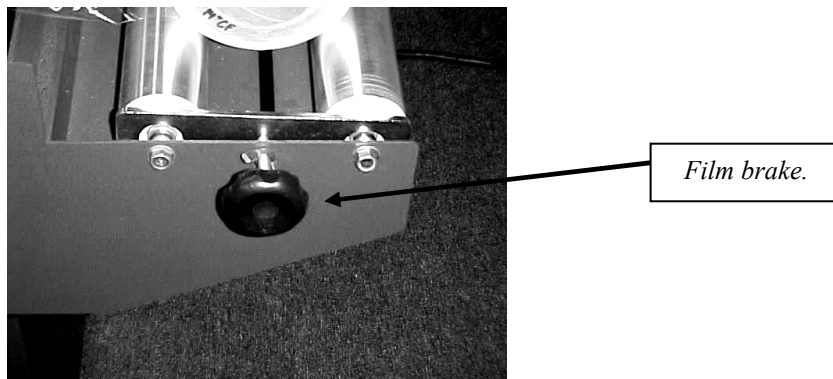

2. Loosen film roll brake.

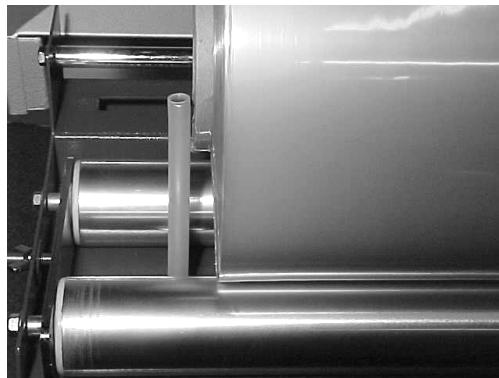

3. Make sure film guide rolls are not restraining roll from turning freely.

TL1622MK-COMBO Service Manual

EXCESSIVE FILM WINDING OR "SPILL"

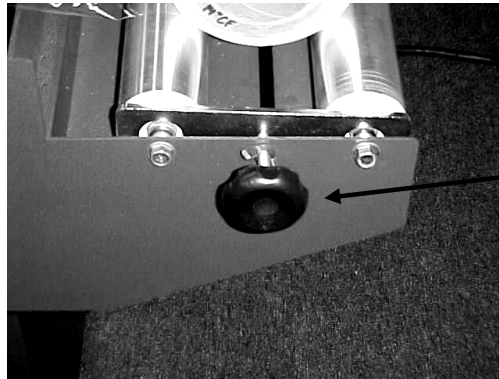

Film brake.

1. Tighten film roll brake.

TL1622MK-COMBO Service Manual

CONVEYOR MALFUNCTION



1. Check main power at machine's main breaker.

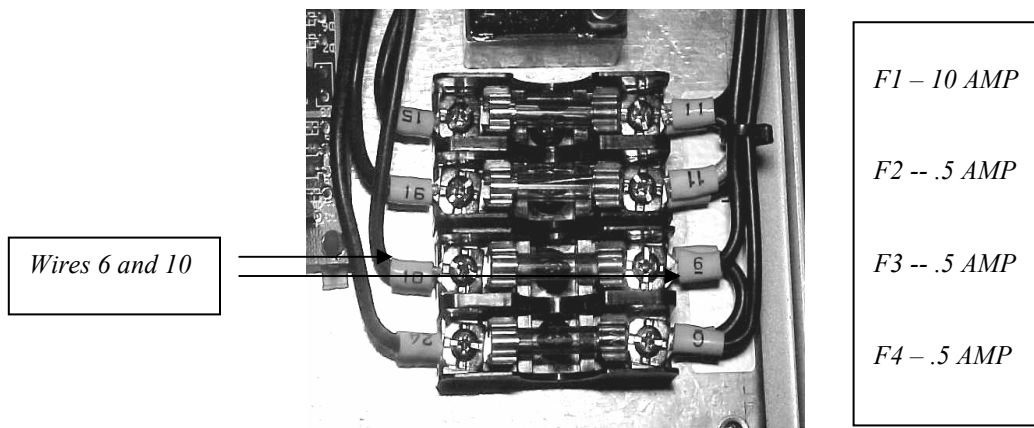

2. Open main panel. Check conveyor motor fuse (F-3/.5 Amp) wires No.6 and 10. If bad, replace.

TL1622MK-COMBO Service Manual

Conveyor malfunction (continued)

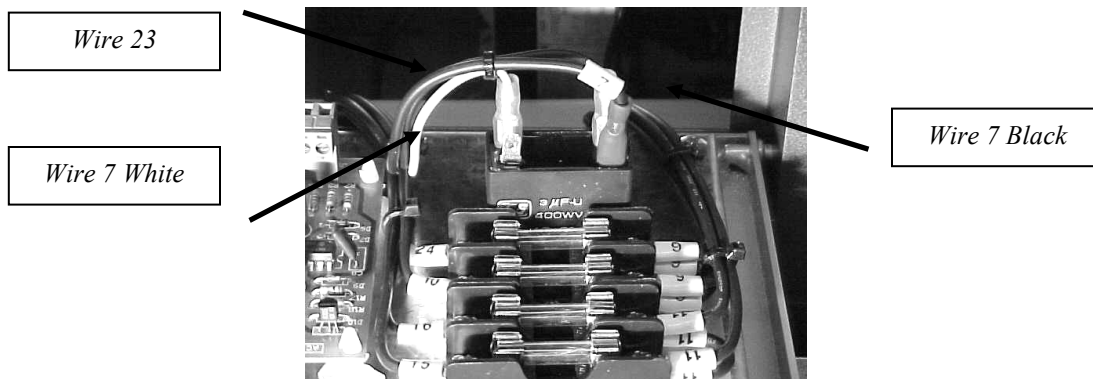

3. Check Motor Capacitor 1.5 mf. Make sure wires #7 (black) #7 (white) and 23 are connected to Capacitor. Check to see if Capacitor is burned.

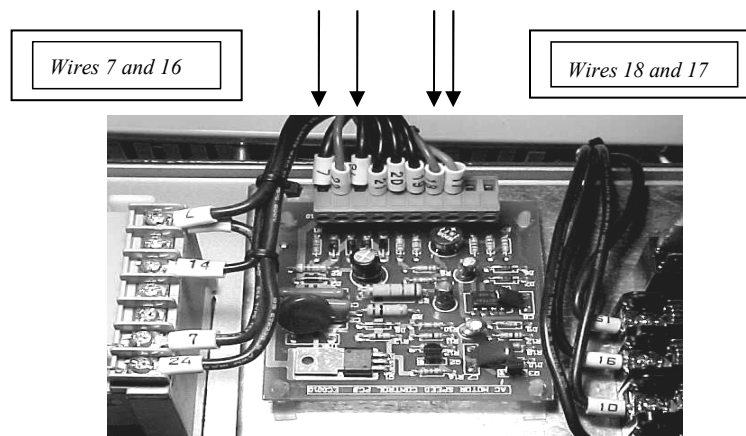

4. Check incoming power on AC Control Board 220 volt, Wires 7 and 16 (Pins 8 and 10). If no power present replace AC board.
 - (a) Check to make sure AC Board is not burned or damaged.
 - (b) If power is present at both locations 7 and 16 and motor does not operate, replace conveyor motor.

TL1622MK-COMBO Service Manual

Conveyor malfunction (continued)

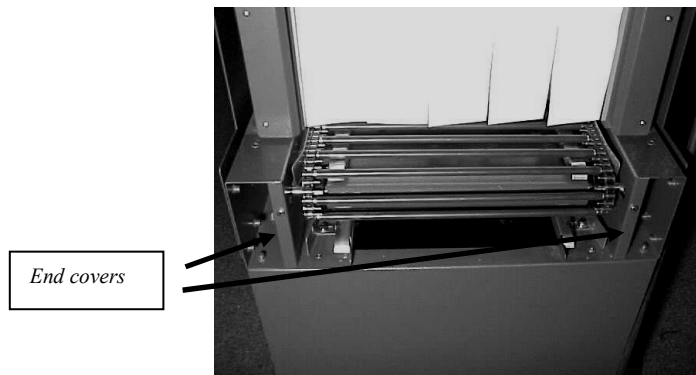

5. Remove end covers and look for obstructed product or lodged rollers.
 - (a) Check lubrication of conveyor chains.

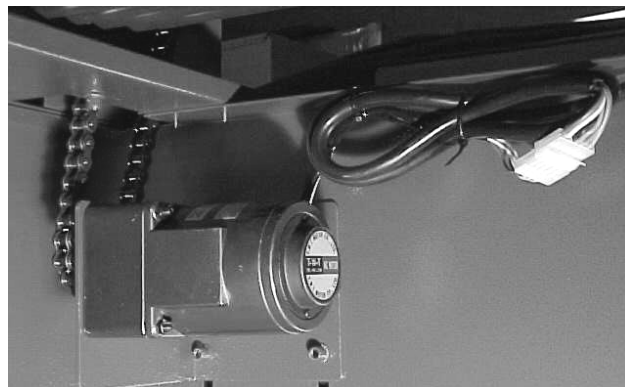

6. Make sure the connection wire on the motor and cable are not loose.
 - (a) Refer to electrical schematic on page 98 for proper wiring of the motor.
 - (b) Check wires 7 and 16 for power. If power present and motor does not operate, replace motor.

TL1622MK-COMBO Service Manual

Conveyor malfunction (continued)



7. Check to make sure the chain is not loose and the sprockets are not touching the frame.
 - (a) Replace the motor if all the above checks properly. See Maintenance, page 96.

NO AIR FLOW



Air velocity knob

TL1622MK-COMBO Service Manual

1. Make sure air velocity knob is not on low.
NO AIR FLOW (continued)

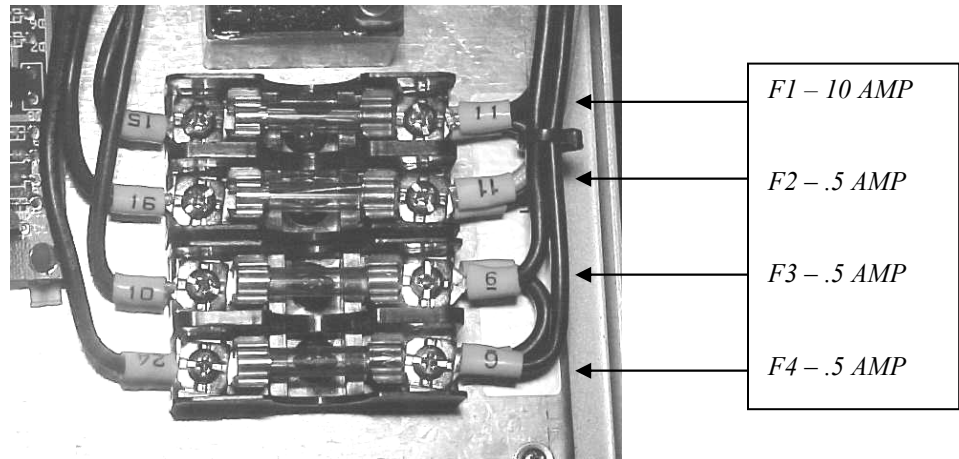

2. Open main electrical panel. Check Blower Motor fuse F-1 (10 amp).
3. Test fuses F1, F2, F3 and F4.



4. Check to make sure no air holes are obstructed due to plastic build up covering air holes.

TL1622MK-COMBO Service Manual

NO AIR FLOW (continued)

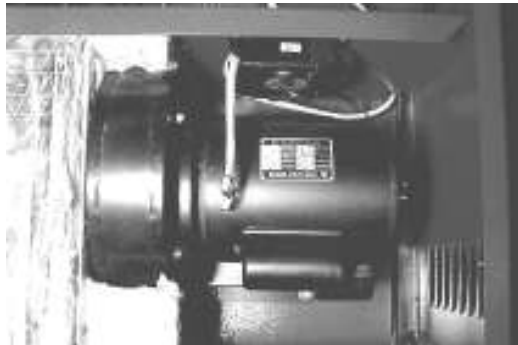

5. Check main blower motor and replace if necessary.
 - (a) Check motor start capacitor to see if burned.
 - (b) Check motor wires 7 and 10 for loose connection.
 - (c) Check for 220 volt power across wires 7 and 10 (motor wires). If voltage is present and the motor still does not operate, replace motor.



6. Check to make sure blower wheel is not loose on the blower motor shaft.

TL1622MK-COMBO Service Manual

NO HEAT

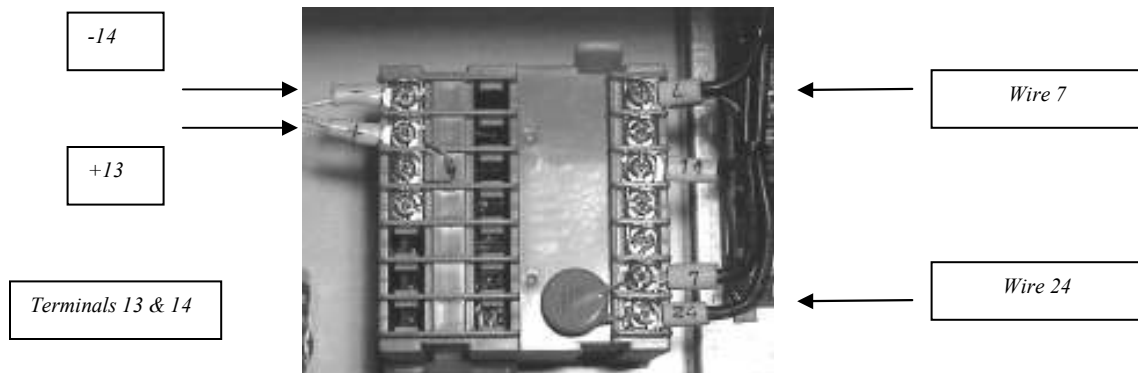

1. Check thermocouple wires at temperature controller (Terminals +13 and -14). First, disconnect, then check with meter for continuity across the two thermocouple wires.
 - (a) If no continuity is present across thermocouple wires, replace thermocouple.
 - (b) Check terminals at 7 and 1 (wires 7 and 24) for 220 Volt power on temperature controller when CR2 is pulled in under set temperature.
 - (c) Check for 220 volt present with heater switch in on position. If no power is present, check Fuse F4, .5 AMP. If voltage present at wires 7 and 24 and Fuse F4 is good, replace Temperature Control.

2. **Please note: Before replacing the Temperature Control, check the TS1 (TS1 NO open; thermo overload for blower motor) and TS2 (TS2 NC closed; heat cool down sensor) for continuity with the lead wires disconnected from sensor.**

Note: When any of the sensors are not functioning properly, this causes the temperature controller to malfunction.

TL1622MK-COMBO Service Manual

NO HEAT (continued)

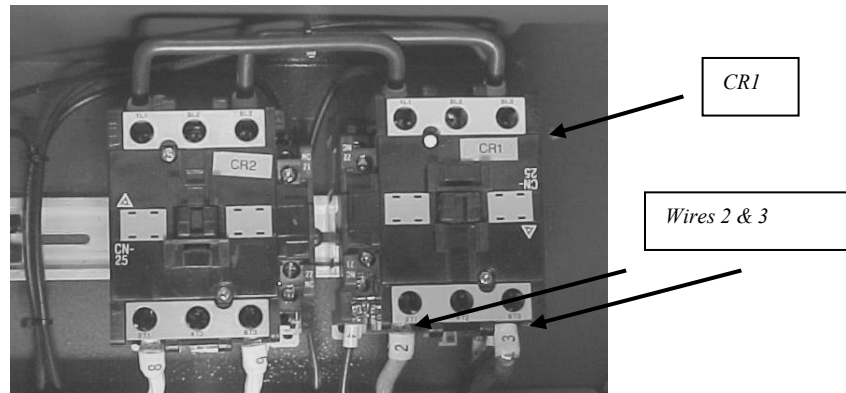

- (a) Check for 220 volt on wires 8 and 9 on CR2 with CR2 contactor pulled in under set temperature. If voltage is present on CR2 contactor on wires 8 and 9, check the Heat Bank for broken lugs or wire inside the Heater Bank. If leads and jumper wires on Heater Bank are not broken or burned, then replace the Heater Bank.



- (b) Check Heater Bank for replacement. Make sure no lugs on the Heater Bank have been broken.

TL1622MK-COMBO Service Manual

NO HEAT (continued)



3. Check the heater bank to make sure the wires are not loose or broken on the heater bank. Pull the heater bank and make sure the heater bank has continuity across wires. If not, replace it.

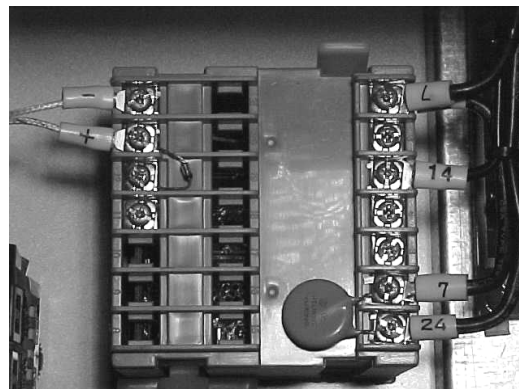

4. If no control over heat, interchange thermocouple wires at temperature controller. If still no control, check for replacement of CR2 or temperature control.

TL1622MK-COMBO Service Manual

MAINTENANCE – L'SEALER PORTION OF MACHINE

MICRO KNIFE BAND RIBBON COMPENSATOR ADJUSTMENT

Adjustment of the band ribbon compensator may be required under the following conditions:



1. During continuous use. After about 15 minutes of sealer operation, check seal quality and, if required, reset compensator. This may be necessary as a result of heat buildup in the sealing head, or stretching of band ribbon.
2. After installing new Band Ribbon, make sure the Band Ribbon lies properly over the entire length of the seal bar in the channel.
3. If charring of film is noted, there is too much heat.
4. If sealing is incomplete, there is not enough heat.

To adjust the band ribbon compensator, refer to the adjustment instructions on the following pages:

TL1622MK-COMBO Service Manual

All Films Except Polyethylene



Adjust the band ribbon compensator (located at the left end of the front seal bar) by loosening the wing nut and turning the knurled-head screw until a 1/4" air gap exists. With folded film (i.e. two layers of film) in the sealing position, bring down the sealing head. Set the seal timer for a 1/2 to 2 setting then examine the seal. Experimentally, in small increments, increase the band ribbon compensator air gap setting until a setting is obtained which yields a satisfactory seal and film cut off. It is important to remember that the smallest air gap at which a satisfactory seal and film cut off is obtained is the correct setting. If using PVC film we recommend using silicone bottom seal sponge.

TL1622MK-COMBO Service Manual

Polyethylene Films



On the band ribbon compensator, loosen the wing nut and turn the knurled-head screw until a 1/4" air gap exists. Tighten the wing nut. With folded film (e.g., two layers of film) in the sealing position, bring down the sealing head. Set the seal timer to position 1 or 2 on the timer dial setting.

Ordinarily, it will not be possible to obtain a satisfactory seal with the 1/4" gap setting. Experimentally, in small increments, increase the band ribbon compensator air gap setting until a setting is obtained which yields a satisfactory seal and film cut off.

TL1622MK-COMBO Service Manual

BAND RIBBON REPLACEMENT

The band ribbon is subject to constant wear and will require replacement as teflon coating eventually wears off. To replace band ribbon, proceed as described below.

Replacing Micro Knife Band Ribbon



1. Loosen Allen screw on backside of compensator to loosen band ribbon.



2. Using a 2mm Allen wrench, loosen corner screw.

TL1622MK-COMBO Service Manual

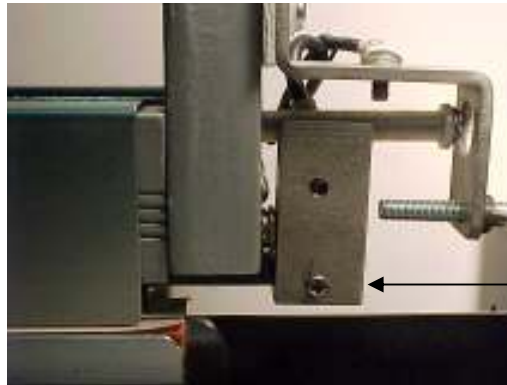

Holding Screw

3. **Loosen screw** holding Band Ribbon in place on front seal bar.



4. Loosen screw on back side of "side" seal bar compensator.

TL1622MK-COMBO Service Manual



Note: Once screw is loosened spring loaded compensator will expand.



5. Remove old micro knife.

TL1622MK-COMBO Service Manual



6. Take new micro knife band ribbon and bend corner approximately 90 degrees.



7. Cut a piece of 3 mill teflon tape and wrap around band ribbon before inserting into corner-block of seal bar.



TL1622MK-COMBO Service Manual

8. Push band ribbon into corner block until it is fully seated at bottom of channel. Cut off excess teflon tape to insure good corner seal.



9. Insert band ribbon into remaining length of channel.



10. Push spring loaded compensator forward and tighten lock screw.

TL1622MK-COMBO Service Manual



11. Cut off excess length of band ribbon.

Important: After replacing Band Ribbon, be sure to adjust the setting of the element compensator. See page 26 for instruction.

TL1622MK-COMBO Service Manual

TAPE REPLACEMENT

The item most subject to wear on the sealer is the teflon tape used to cover the silicone sponge rubber on the sealing bar. This $\frac{3}{4}$ " x 10 mill tape should never be permitted to burn through. To replace tape, proceed as follows:



1. Strip off old tape.
2. Cut off proper length of new teflon, peel off backing, and press new tape into position.
3. Apply $\frac{1}{2}$ " x 10 mill Teflon tape over the top of the $\frac{3}{4}$ " Teflon tape.

TL1622MK-COMBO Service Manual

SILICONE RUBBER SEALING PAD REPLACEMENT

Occasionally it will be necessary to replace the silicone rubber sealing pads. This should be done if the following is noted:

- Gaps in the seal
- Weak seals
- Improper film cut-off
- Excessive sealing pressure required

To replace rubber, proceed as follows:



1. Seal pads are designed with a channel for easy replacement. Pull silicone rubber out of the channel.
2. Replace with new silicone rubber. Press rubber back into channel.
3. Install 3/4" - 10 mil teflon tape on top of rubber.
4. Install 1/2" - 10 mil teflon tape over the 3/4" tape.

TL1622MK-COMBO Service Manual

Sealing Pad Pressure Adjustment for Head Return Cylinder

Uniform pressure between the sealing elements and the sealing pads must always be maintained for proper sealing uniformity, and to prevent element hot spots and premature burnout. This adjustment should be checked periodically and should always be checked when sealing gaps occur. Proceed as follows:

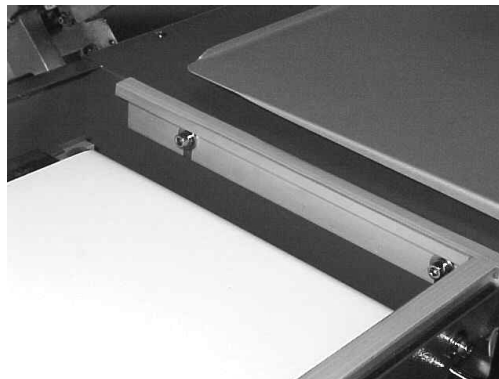

1. Loosen all five bolts on lower pads just enough to maintain a moderate sliding pressure.



2. With sealing head resting on lower pads, make sure there are no air gaps, then tighten the five bolts on the lower pad.
3. Adjust magnets (see page 78 for magnet adjustment).

TL1622MK-COMBO Service Manual

Adjust Height of Seal Bar

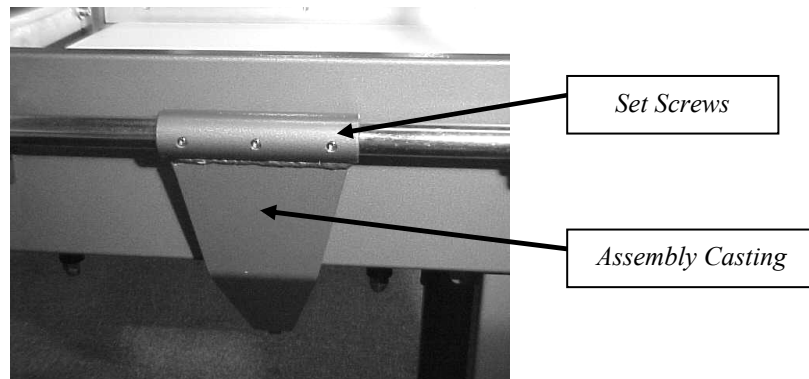

4. To raise or lower seal bar height, adjust seal head cylinder assembly casting by loosening the three set screws on shaft. Move assembly casting forward or backward, then reset seal head by locking set screws.



5. Cycling head up and down, adjust set screw for proper head speed and cushion.

TL1622MK-COMBO Service Manual

Band Ribbon Pulse Switch Adjustment

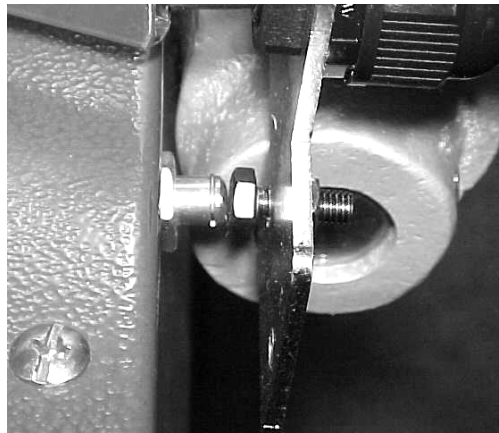

The sealing cycle should not begin until the sealing head is within 1/4" or less of the film to be sealed. If the magnets energize before the head is within 1/4" of the film, loosen the lock-nut and turn the screw (located at the rear end of the side seal bar) up slightly (counterclockwise when viewed from above). The correct adjustment has been obtained when the magnets energize just as the seal bar comes into contact with lower pads.

TL1622MK-COMBO Service Manual

Adjustment of Magnets for Correct Sealing Pressure

All magnets have been factory adjusted for equal sealing pressure throughout the length of both the front and side seal bars. However, if an adjustment is required, proceed as follows:

1. Disconnect the sealer's power source.

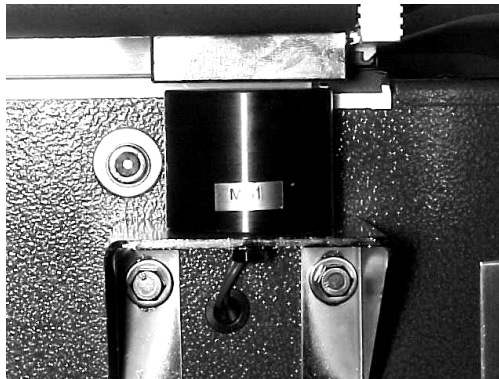

2. Loosen the lower magnet bolts on all lower magnets so that the magnets settle to their lowest position in the mounting slots.
3. Lower the sealer's operating handle fully and lift lower magnets to within 1/16" from the holders. Tighten the mounting bolts securely to retain the proper adjustment.

TL1622MK-COMBO Service Manual

Conveyor

From time to time, it will be necessary to disassemble the conveyor as it will need adjustments or replacement of worn parts and general maintenance. The following information is given to assist the operator in that general fashion. If the problem does not rectify itself with this general explanation, discuss it with an authorized distributor of TRULINE Packaging or with TRULINE Packaging directly.

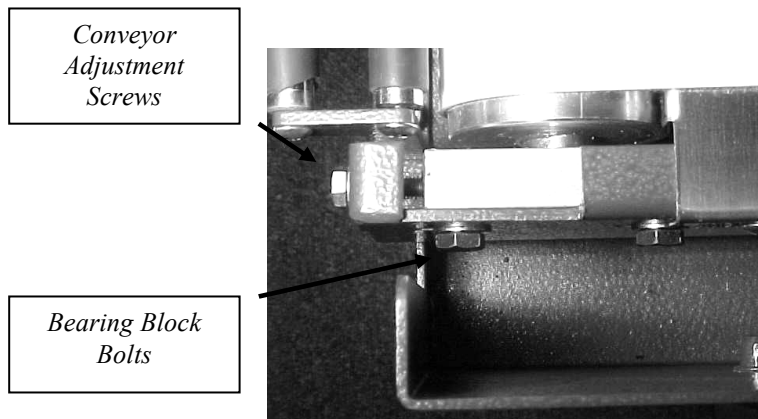

- A. Adjust Discharge Conveyor Belt by loosening the Bearing Block Mounting Bolts, then adjust the Conveyor Adjustment Screw in to loosen belt, or out to tighten belt.

TL1622MK-COMBO Service Manual

Replacing Conveyor Motor

1. Disconnect power plug from source of power.



2. Disconnect the three power wires from the rear of the motor.
3. Loosen the four bolts that hold the motor mount bracket to the conveyor and slide motor mount forward.
4. Loosen set screws on sprocket that are attached to the motor and remove sprocket.
5. Remove four bolts. These bolts hold the motor in place. Hold motor while removing these bolts so the motor does not drop.
6. Follow steps 2-5 above in the opposite order to reinstall new motor against the conveyor frame and tighten set screws.

TL1622MK-COMBO Service Manual

Replacing Front and Side Seal Bars

1. Turn power switch to off position.

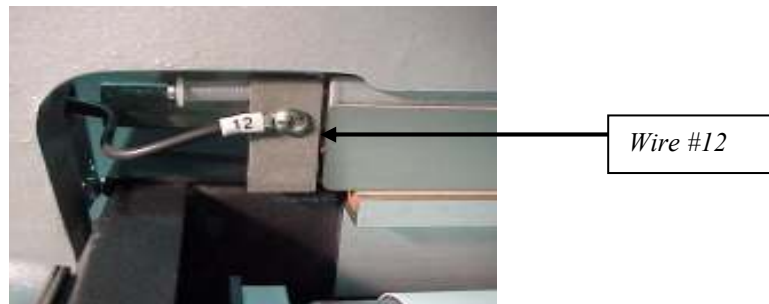

2. Remove wire #12 from side bar compensator.

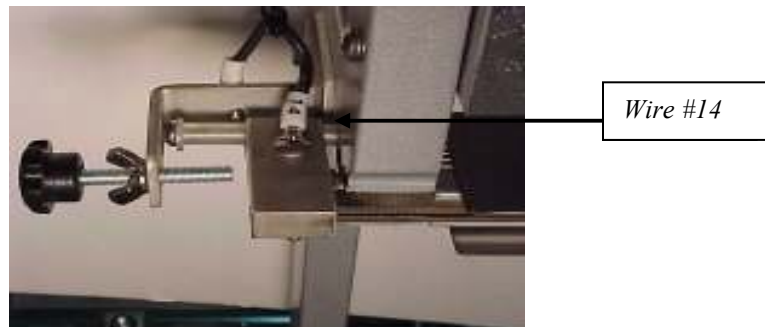

3. Remove wire #14 from front bar compensator.

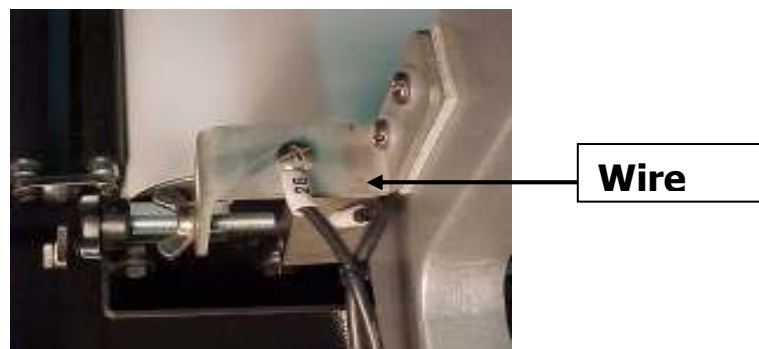

4. Remove wire #26 from temperature control bracket.

TL1622MK-COMBO Service Manual

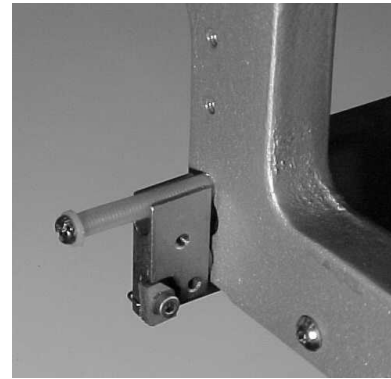

5. Remove temperature control bracket.
NOTE: Bracket is held in place with two screws. Also, **do not** lose the insulators.

6. Compress front bar compensator all the way in using your thumb and hold. Loosen Allen screw on compensator holding Band Ribbon.
Warning: Remove compensator slowly, applying tension, as compensator is spring loaded.

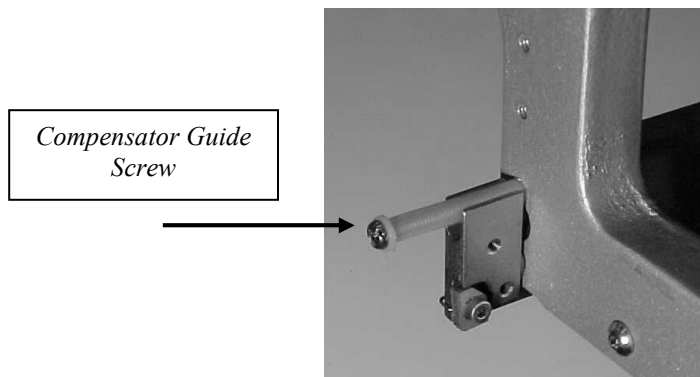

7. Remove compensator guide screw.

TL1622MK-COMBO Service Manual



8. Remove Allen Bolt holding front seal bar to the outfeed bar.

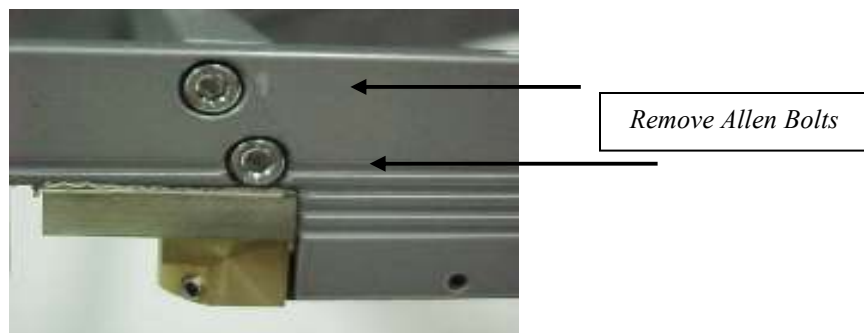

9. Remove bolts holding side seal bars to casting.
10. Remove seal head from entrance casting and outfeed bar.



11. Remove the side bar compensator following steps 6 and 7.

TL1622MK-COMBO Service Manual



12. Remove upper magnet holder on side bar.
13. Remove handle.

TL1622MK-COMBO Service Manual

INSTALLATION OF TRANSITE CHANNELS

Front and Side Seal Bar



1. Install corner block.

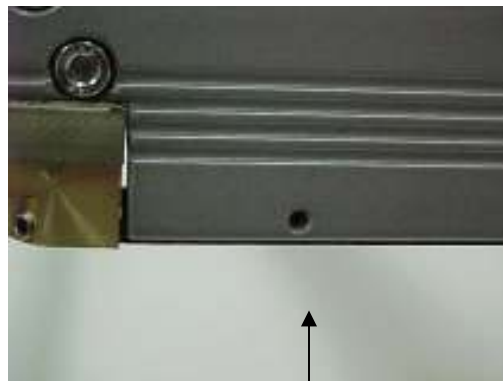

Channel Holding Screw

2. Remove the Allen screws holding channels in seal bar.

TL1622MK-COMBO Service Manual



3. Remove Allen screw.



4. Remove transite channel and replace.

TL1622MK-COMBO Service Manual

Installation of Band Ribbon Compensators and Temperature Control Bracket

1. Lightly grease two compensator springs and put on each seal bar.

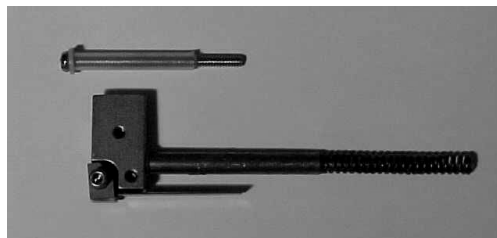

2. Insert compensator and compress in all the way.

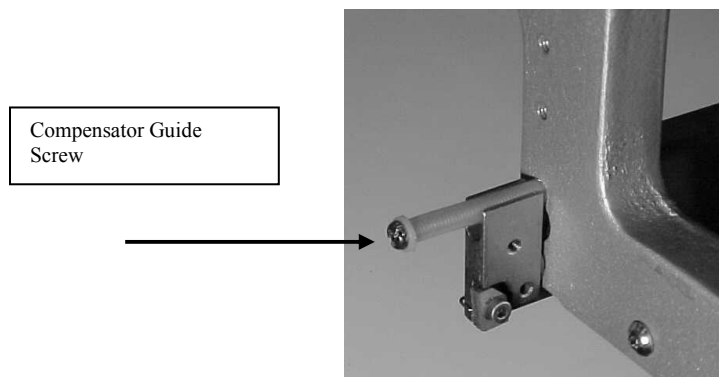

3. Install compensator guide screw assemblies.

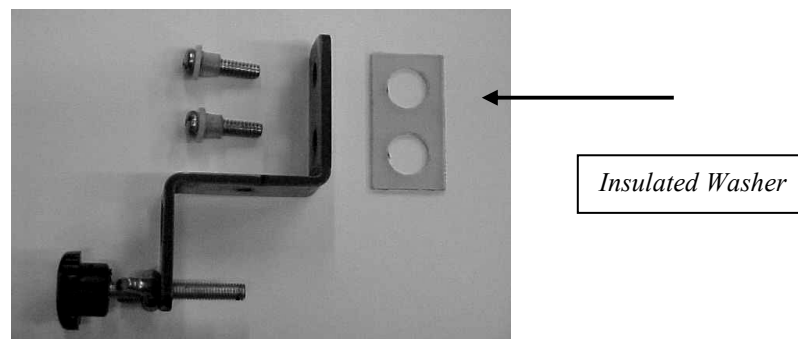

TL1622MK-COMBO Service Manual

4. On the front bar, install the temperature adjustment bracket.
Important: The temperature adjusting bracket must be insulated from the casting to work properly.
5. Install new band ribbon and reset temperature adjustment screw assembly.
6. Reconnect wires to seal head assembly.
 - (a) On the side seal bar, connect wire #12 to compensator block.



- (b) Connect wire #13 to infeed casting.



TL1622MK-COMBO Service Manual

- (c) On the front bar, connect wire #14 to the compensator block.



- (d) On the temperature adjusting bracket wire #26.



7. Install upper magnet holder on side bar.
8. Install handle and tighten set screws on each end.
- 9. Double check all work done before starting the machine.**

TL1622MK-COMBO Service Manual

MAINTENANCE – TUNNEL PORTION OF MACHINE

To aid in maintaining the high reliability of this shrink tunnel, the following maintenance should be provided.

**DISCONNECT ALL POWER BEFORE MAKING ANY REPAIRS.
IF UNSURE OF ANYTHING, CONTACT
A QUALIFIED SERVICE TECHNICIAN**

- A. The conveyor chains should be lubricated once a month with a high temperature oil. The lubricant should be applied with a brush or sprayed while the conveyor is slowly running.
- B. The silicone covering on the tunnel rollers should be inspected regularly to assure that no scrap pieces of film are wrapped around the rollers to cause sticking of packages. To clean, run conveyor until the affected rollers are within the heated chamber, thus heating the film residue to soften the film, then advance the conveyor to stop the rollers outside the heat chamber for cleaning. Make sure the conveyor is stopped before putting your hands or anything else in the conveyor area. If necessary to remove the film residue, use a dull, blunt-edged tool. Do not use any sharp instruments, as nicking the silicone may result in having to replace the roller covering.
- C. To replace silicone covering on the roller, proceed as follows:

TL1622MK-COMBO Service Manual

Replacement of Conveyor Rollers

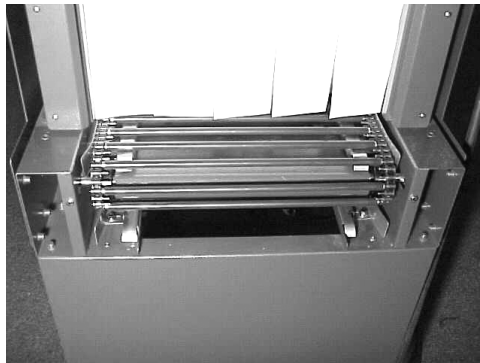

- D. Remove idler end caps.



- E. Loosen the two take up bolts for the chain adjustment giving yourself enough slack to pull chain upward and spread chain apart to remove roller. See picture on page 92.

TL1622MK-COMBO Service Manual



Now you are ready to move the rollers.

- F. Remove old roller covering by very carefully slitting the covering and pulling off.
- G. Clean all rollers, using steel wool or a wire wheel. Make certain all rollers are smooth and free of residue or burrs.
- H. Fit the new silicone rubber tubing onto each roller and work on by hand at least 1/2". At the opposite end of the tubing, attach and secure an air supply hose of low pressure, maximum pressure 5 lbs. While the tubing is slightly expanded by the air pressure, push the tubing onto the roller. Be very careful to hold the roller at all times so it does not escape due to the air pressure.
- I. Replace rollers on conveyor by inserting roller end holes into the extended pins on the chain
- J. Check conveyor chain tension as described on page 93.

TL1622MK-COMBO Service Manual

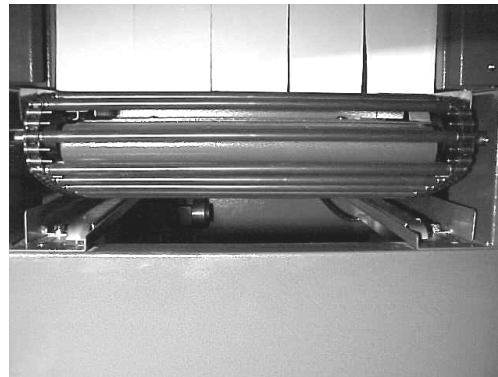

Roller at 3 o'clock position

- K. The adjustment of package conveyor chain tension should be checked occasionally to ensure that it is not excessive, as this would cause unnecessary wear of the sprockets. To check or adjust tension, shut off power to the tunnel. Remove idler end caps. Adjust conveyor to these specifications. On the idler end of the conveyor, bring a roller to the three o'clock position (the center of the end of the conveyor). From that point count seven roller in; the seventh roller should be evenly touching the conveyor roller bottom rails.

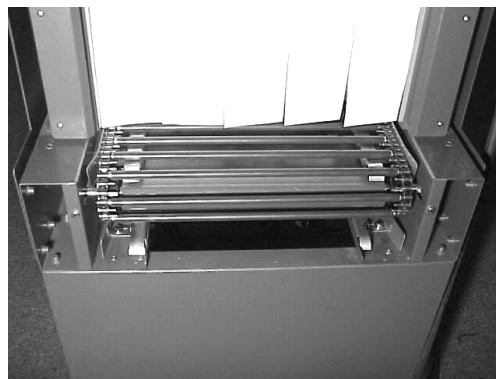

TL1622MK-COMBO Service Manual

- L. **Replacement of idler roller shaft, bearings, or sprockets.** Remove idler end caps to gain access to idler shaft. Disconnect the conveyor chains by removing the master links. Remove two bolts from the idler block holder and shaft assembly should pull right out. Remove two tension bolts from idler block holder, then the shaft and sprockets will come right off. Replace and reassemble in the same manner as disassembled.

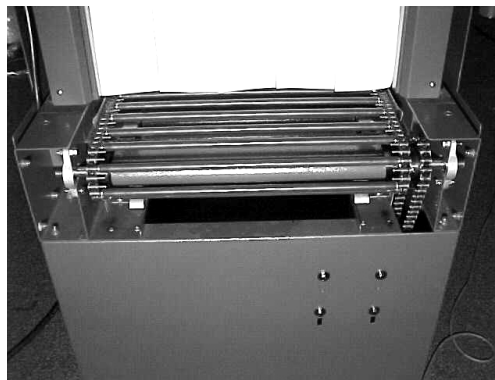

TL1622MK-COMBO Service Manual

M. **Drive shaft, bearings, or sprockets replacement.**

- (1) Remove drive end caps instead of idler end caps.
- (2) Disconnect the conveyor chain by removing the master links.

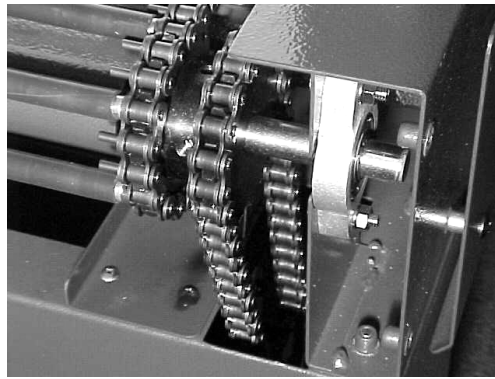

- (3) Remove two bolts from the flange bearings and remove drive shaft assembly.
- (4) The drive shaft has one sprocket pinned to it and must be reinstalled the same way. The other sprocket and bearings will slide right off the drive shaft. Replace and reassemble.

TL1622MK-COMBO Service Manual

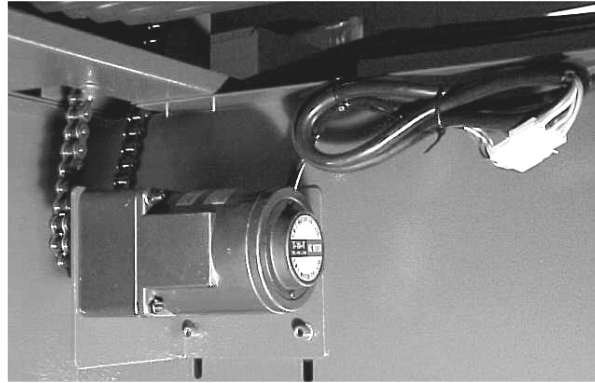

N. Conveyor motor replacement.

- (1) Disconnect power to machine.
- (2) Disconnect electrical wires from drive motor, and remove four bolts that hold the drive motor.
- (3) Remove sprocket from old motor and place on new drive motor. Reassemble in the same manner it was disassembled. For wire hook up refer to electrical schematic on page 108.

TL1622MK-Combo Service Manual

0. **Heater bank replacement.**

- (1) Shut off power to machine.



- (2) Remove left side safety shield and panel.

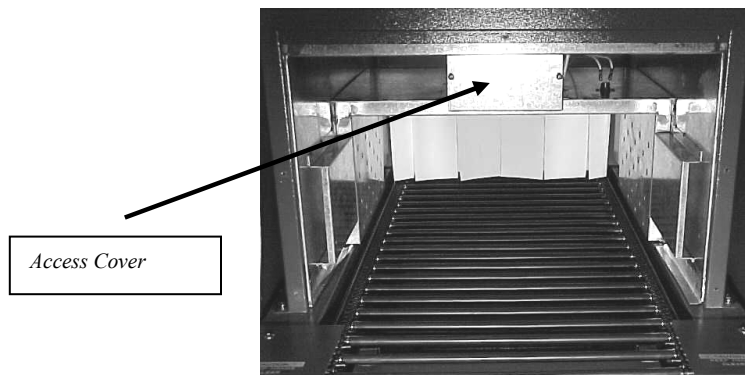

- (3) Remove access cover and pull insulation out.

TL1622MK-Combo Service Manual

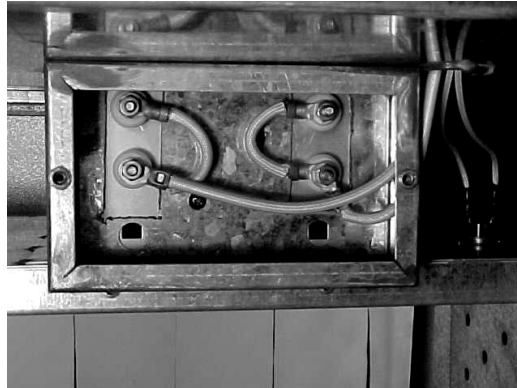

- (4) With a 3/8" nut driver, remove wires on the heater bank. Set wires off to side.
 - (a) Remove heater bank terminal box from the heater bank.



- (5) Then remove heater bank.
- (6) Place the heater bank terminal box on the new heater bank. Reassemble in the same manner it was disassembled.

TL1622MK-Combo Service Manual

P. Temperature controller replacement.

- (1) Shut off power to machine.
- (2) Open main panel door.

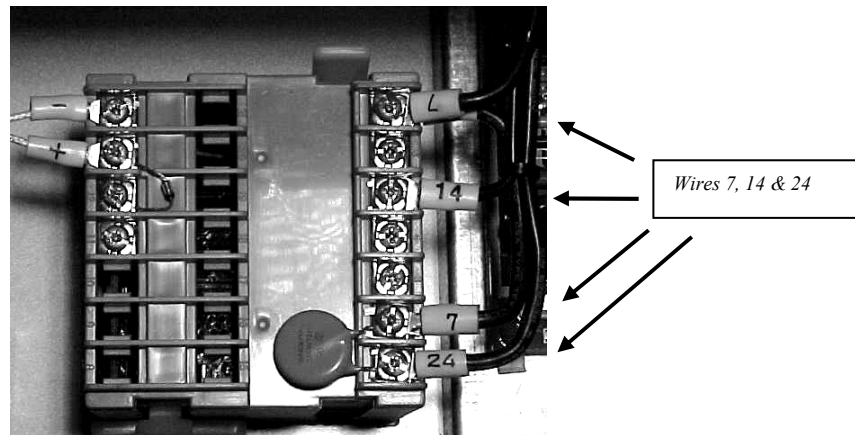

- (3) Disconnect four wires (Two Nos. 7, 14 and 24) and thermocouple wires from temperature controller.
- (4) Loosen screws on side of controller itself and pull controller out of the front of the panel. Replace with new controller. Refer to electrical schematic for replacement of four wires (Two Nos. 7, 14 and 24) and thermocouple wires.

WARNING: IF NO CONTROL OVER HEAT, INTERCHANGE THERMOCOUPLE WIRES.

CAUTION! DO NOT EXCEED 500 DEGREES.

TL1622MK-Combo Service Manual

Q. Blower Motor Replacement.

1. Shut off power to machine.

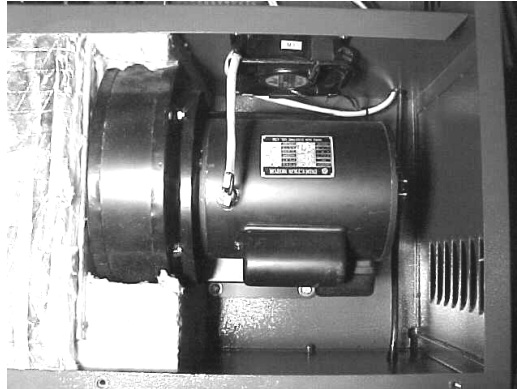

2. Remove top panel and 4 screws holding the blower chamber cover.
3. Disconnect wires on the blower motor.

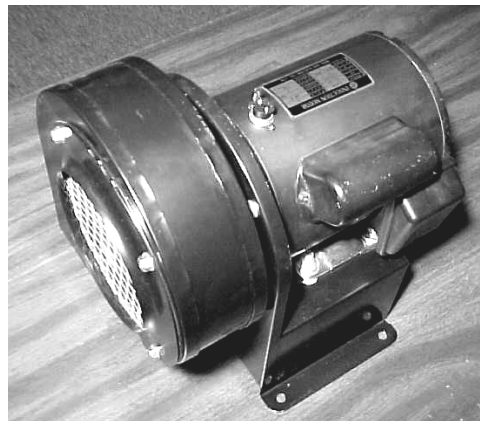

4. Remove four bolts at motor base.

TL1622MK-Combo Service Manual



5. Once blower housing is on a bench, loosen the four bolts holding the blower wheel screen and remove screen.

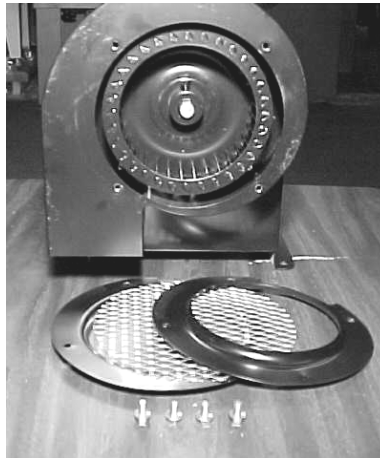

6. Remove outer screen covering of Blower Wheel Housing.



7. Remove Bolt Holding Blower wheel to Blower Motor.

TL1622MK-Combo Service Manual

Note: This housing should be tested outside the tunnel to assure that it works. Reassemble in the same manner as disassembled. (If force is necessary, apply it between the motor and the blower wheel hub.) Now remove the motor mount bolts and remove/replace motor. Reassemble new motor and blower wheel housing.

TL1622MK-Combo Service Manual

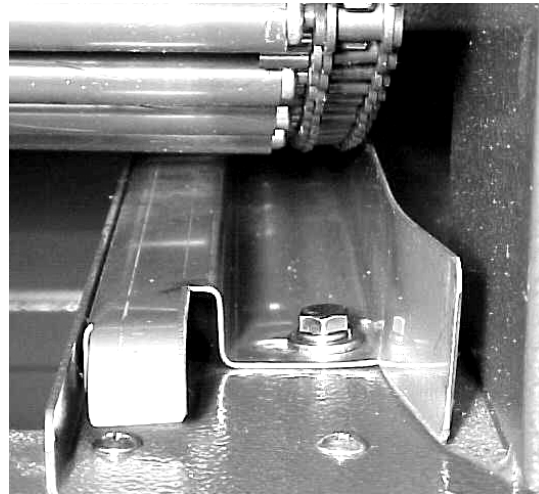

R. Wear rails lower adjustments.

1. Disconnect power to machine.
2. Remove idler and drive end caps. Loosen the two bolts holding each wear rail underneath conveyor, and slide rails over towards center. There should be 1/16" to a max. of 1/8" clearance between conveyor chain and roller. Retighten the two bolts.

S. Wear rails lower replacement.

1. Disconnect power to machine.
2. Remove idler and drive end caps.
3. Remove two bolts underneath conveyor from each wear rail and slide rails out.
4. Slide new rails in; reassemble and readjust.

TL1622MK-Combo Service Manual

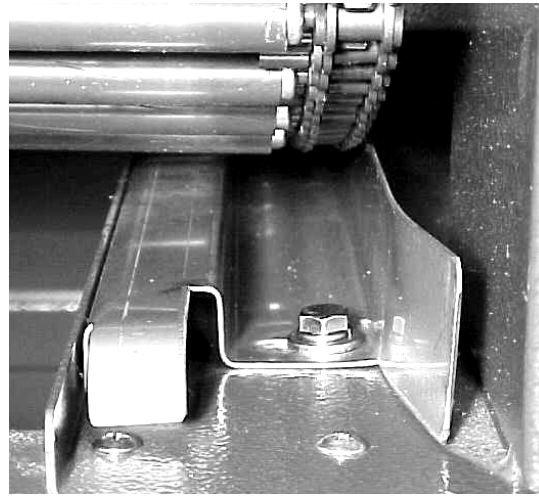

5. Wear rail should be 1/8" from edge of chain then tighten bolt to secure wear rails.
- T. **Wear rails upper adjustments.**
1. Disconnect power to machine.
 2. Remove drive and idler end caps.
- Note: Take out only ten rollers, then move the open space to one end. Loosen the one bolt that hold rail in place. With a screw driver, pry rail over towards the center. Do the same on all four corners. Spin conveyor by hand and check clearance between chain and roller. The distance should be about 1/16". Then tighten the two bolts on each rail.

TL1622MK-Combo Service Manual

U. Wear rail upper replacement.

1. Disconnect power to machine.
2. Remove drive and idler end caps.

Note: Take out only top half of rollers, then move the open space to expose upper wear rails. Remove the two bolts that hold rails in place. Pull out rails and replace with new rails; reassemble and readjust.

IF UNSURE OF ANYTHING, CONTACT A QUALIFIED SERVICE TECHNICIAN.

DOUBLE CHECK ALL OF YOUR WORK BEFORE RESTARTING THE MACHINE.

TL1622MK-COMBO Service Manual

**ELECTRICAL PANEL DIAGRAM
CONTROLS FOR TL1622MK-COMBO
TUNNEL PORTION**

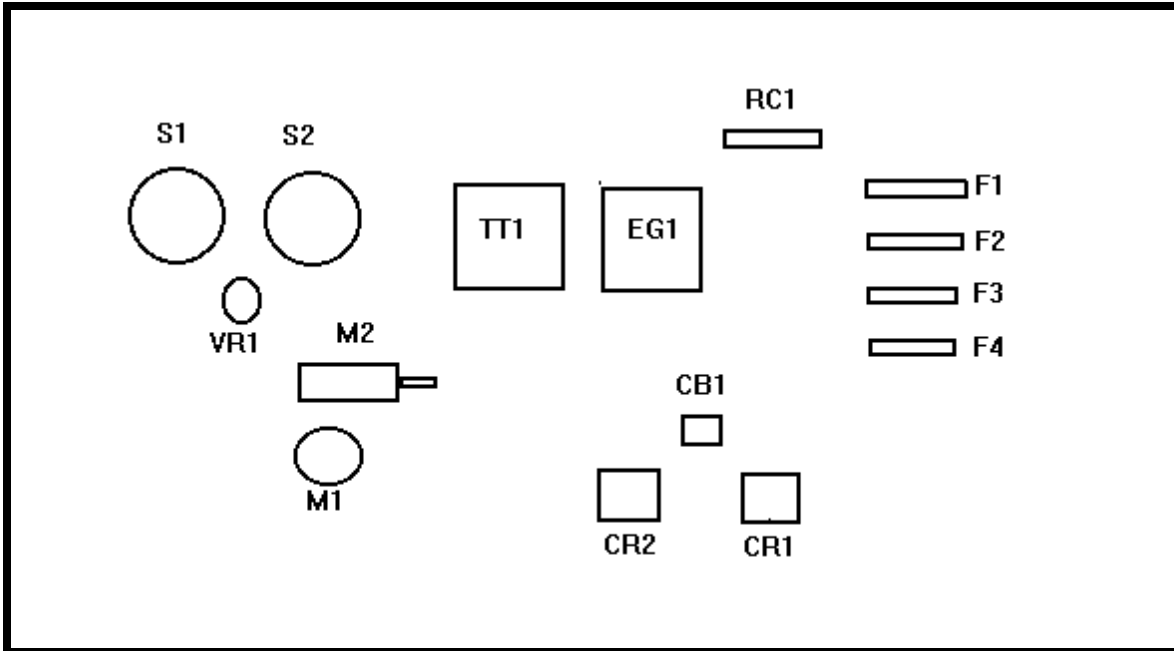

TL1622MK-COMBO Service Manual

**ELECTRICAL PANEL DIAGRAM
CONTROLS FOR TL1622MK-COMBO
SEALER PORTION**

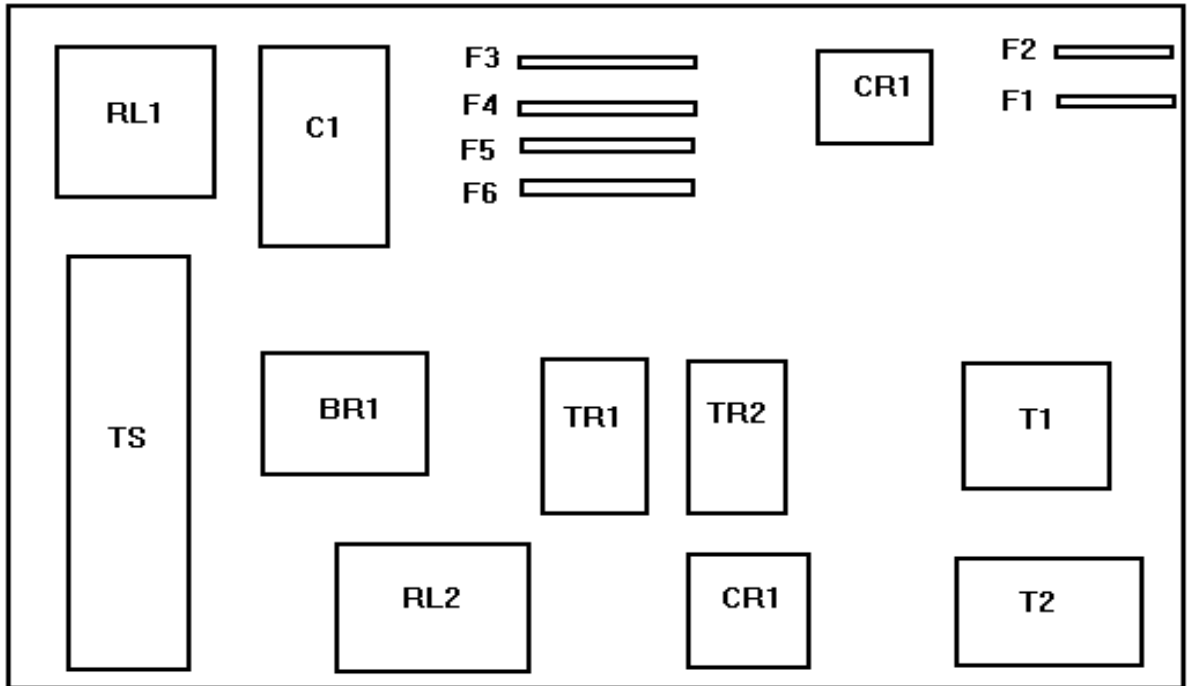

TL1622MK-COMBO Service Manual

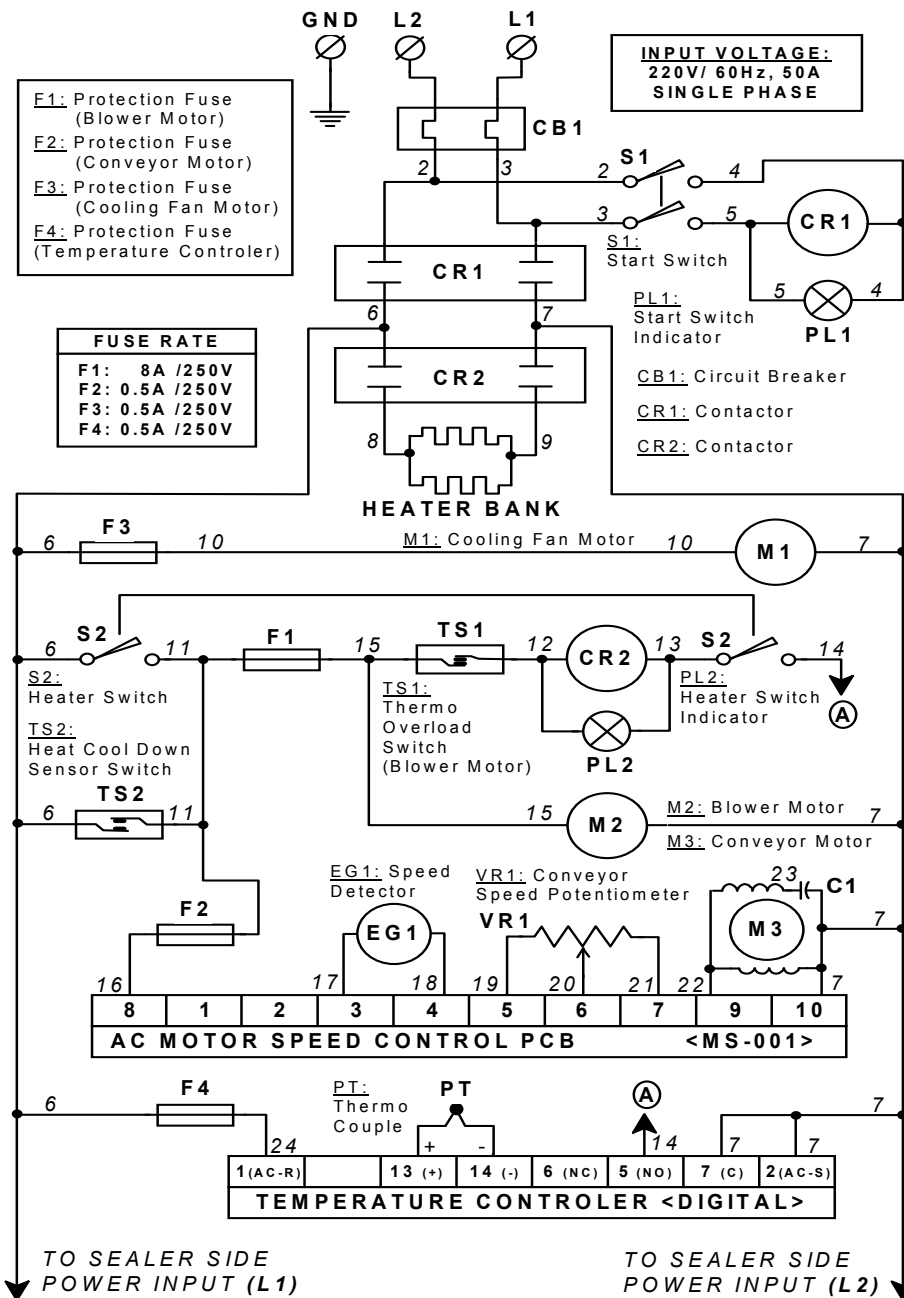

MODEL: TL1622MK-COMBO (220V) << TUNNEL SECTION >>

TL1622MK-COMBO Service Manual

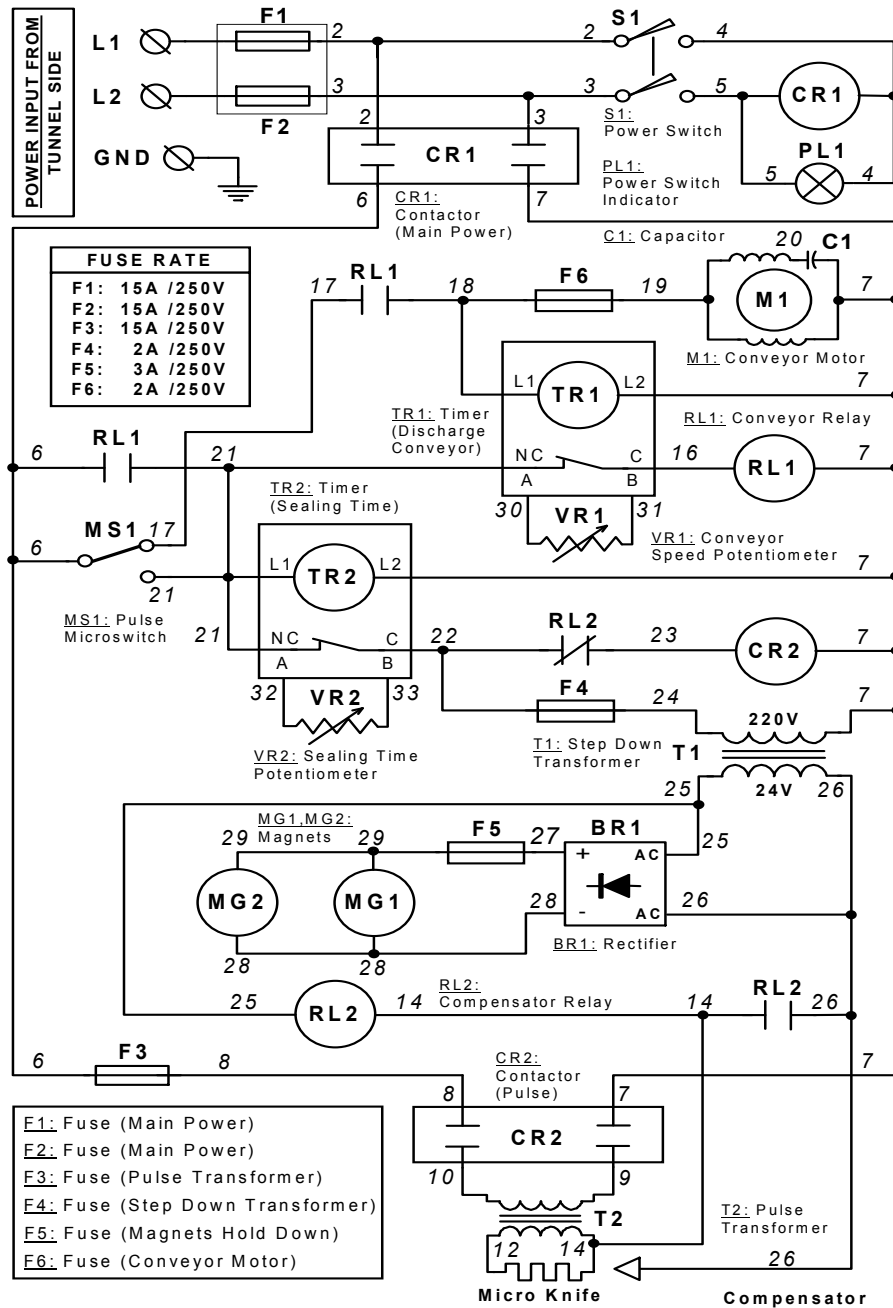

MODEL: PP1622MK-COMBO (220V) <<SEALER SECTION>>

TL1622MK-COMBO Service Manual

**PARTS LIST NOMENCLATURE
TRULINE PACK MODEL TL1622MK-COMBO
TUNNEL PORTION**

Item	Part #	Qty	Parts List Nomenclature
M1	1722-37	1	Cooling Fan Motor
M2	1722-36	1	Main Blower – ½ HP, 208-240 Volt
M3	3500-08	1	Conveyor Motor AC (25W)
CR1	3400-13	1	Contactor – 3 Pole, 208/240 Volt, 35 AMP
CR2	3400-13	1	Contactor – 3 Pole, 208/240 Volt, 35 AMP
TC-003	3500-75	1	Temperature Controller
Heater	1720-05	1	Heater Bank
RC1	3500-02	1	Capacitor, 3 MF, 400 VAC
EG1	3500-25	1	Speed Detector Conveyor Motor
ACT	3600-30	1	AC Terminal
VR1	3400-68	1	Speed Potentiometer – Conveyor Motor
TS1	3600-35	1	Thermo Overload Sensor (S-90)
TS2	3500-46	1	Heat Cool Down Sensor (B-100)
CB1	3500-19	1	Circuit Breaker, 40 AMP
F2, F3, F4	3500-14	3	.5 AMP
F1	3500-15	1	10 AMP
PL1	3600-05	1	Pilot Light 220 Volt Start Switch
PL2	3600-10	1	Pilot Light 220 Volt Start Switch
PT	3600-15	1	Thermocouple
S1	3600-20	1	Switch – Start
S2	3600-25	1	Switch – Heater
MS001	3500-12	1	AC Conveyor Motor Speed Control

TL1622MK-COMBO Service Manual

**1622MK-COMBO REPLACEMENT PARTS LIST
TUNNEL PORTION**

Part #	Qty	Description	Price
3500-35	4	Adjustable Leveling Bolts	
3500-36	2	Bearing – Drive Shaft Mounting	
1722-36	1	Blower Motor ½ HP	
3500-47	1	Blower Motor -Housing	
3500-03	1	Blower Wheel	
1722-37	1	Cooling Fan Motor	
3500-04	4	Caster	
3500-02	1	Capacitor, 3 MF, 400 VAC	
3500-19	1	Circuit Breaker – 40 AMP	
3500-05	2	Chain – Master Link #40 – Extended Pin	
1722-24	1	Chain – Master Link #40	
3500-37	2	Chain Tension Adjustment Bolt	
	1	Chain – Tunnel Height Adjustment	
3500-06	28	Chain -- #40 – Extended Pin – Conveyor (per ft.)	
1722-23	1.5	Chain -- #40 – Rivited-Motor to Drive Shaft (per ft.)	
3400-13	2	Contactoer – 3 Pole – 50 AMP	
3528-07	1	Conveyor Belt – Stainless Steel–Wire Mesh (Belt Only)	
3528-00	1	Conveyor Belt – Teflon Mesh Belt (86")	
3528-01	1	Conveyor Belt – Mesh Belt Clamp Bar	
3500-08	1	Conveyor Drive Motor AC (25W)	
3528-10	2	Curtain Material Set (one end)	
3500-11	1	Drive Shaft	
3500-12	1	AC Electrical Board – Complete	
3500-38	1	End Covers – Drive Side (Left)	
3500-39	1	End Covers – Drive Side (Right)	
3500-40	1	End Covers – Idler Side (Left)	
3500-41	1	End Covers – Idler Side (Right)	
3500-14	1	Fuse F1 -- 10 AMP	
3500-42	1	Fuse – F2, F3, F4- .5 AMP	
3500-16	1	Fuse Block	
3400-31	1	Fuse Holder	
	2	Gear – Adjustment for Tunnel Height	

TL1622MK-COMBO Service Manual

Replacement Parts List – Tunnel

Part #	Qty	Description	Price
3500-75	1	Handle – Adjust Tunnel Height	
3500-45	1	Heater Bank – Mounting Box	
1720-05	1	Heater Bank – 7.5 KW	
3500-46	1	Heat Sensor – B-100 NC—Tunnel Cool Down – TS2	
3500-35	1	Heat Sensor – S-90 NC Thermal Overload Blower Motor – TS1	
1721-18		Hole Plug Buttons – 3/8” – Nickel	
3500-47	1	Housing – Blower Motor	
3500-17	1	Idler Shaft	
3500-48	8	Lugs – High Temperature Heater Wire	
3600-05	2	Pilot Light – 220 Volt	
3500-49	1	Power Cord – 10 feet	
3500-50	1	Power Cord Connector	
3500-51	2	Rails – Upper/Wear Rails	
3500-52	2	Rails – Lower Wear Rails	
3500-23	54	Roller 16” -- Covered 54 (Hi density 80)	
3500-53	1	Safety Shield – Right End	
3500-54	1	Safety Shield – Left End	
3500-55	1	Safety Shield – Front	
3500-56	1	Safety Shield – Back	
3500-57	6	Safety Shield – 1” End Spacer	
3500-58	2	Safety Shield – Front/Back Spacer 1 ½”	
3500-59	5	Front/Back Spacer ½”	
3500-60	5	Front/Back Mount Screw 1”	
3500-61	6	Safety Shield – End Mounting Screw 1 ½” L	
3500-62	2	Safety Shield – Front/Back Mounting Screw 2”	
3500-63	6	Screw – Tunnel Hood Top 10 mm	
3500-64	1	Screen – Blower Wheel	
3500-65	1	AC Speed Control Potentiometer	
3500-26	2	Sprocket – Conveyor Drive	
3500-27	2	Sprocket – Conveyor Idler with Bearing	
3500-28	1	Sprocket – Conveyor Motor	
3500-20	1	Switch – Start S1	
3500-21	1	Switch – Heater Bank S2	
3600-30	1	Switch – Delay Cool Down Thermoswitch	

TL1622MK-COMBO Service Manual

Replacement Parts List – Tunnel

Part #	Qty	Description	Price
3500-75	1	Temperature Controller	
3400-79	1	Terminal Strip – Short – 3 Lug	
3500-29	1	Thermocouple Probe Holder	
3500-30	1	Thermocouple Probe	
	4	Threaded Rods	
3500-31	1	Velocity Control Knob	
3500-32	1	Velocity Control Shaft	
3500-70		Wire – High Temperature	

TL1622MK-COMBO Service Manual

**PARTS LIST NOMENCLATURE
TRULINE PACK MODEL TL1622MK SEALER**

Item	Part #	Qty	Parts List Nomenclature	Price
S1	3400-45	1	Power On/off Switch	
C1	3500-02	1	Capacitor – 3 MF 400 VAC	
CR1	3400-13	1	Contactor Main Power	
T1	1524-27	1	Stepdown Transformer – 220 Volt/24 Volt	
M1	3400-16	1	Conveyor Motor	
TR1	3400-76	1	Timer – Conveyor	
CR2	3400-12	1	Contactor Pulse – 220 Volt	
LS	3400-47	1	Pulse Limit Switch	
BR1	1720-19	1	Rectifier	
MAG 1 & 2	3400-76	2	Magnets Hold Down	
TR2	3400-77	1	Timer – Sealing	
RL1	3400-57	1	Conveyor Relay – 220 Volt	
RL2	3400-56	1	Compensator Relay – 24 Volt	
T2	3400-55	1	Pulse Transformer – 220 Volt	
F1, F2, F3	3400-28	2	Fuse – 15 AMP 250 Volt	
F5	3400-86	1	Fuse – 3 AMP 250 Volt	
F4 & F6	3400-27	1	Fuse – 2 AMP 250 Volt	
VR1, VR2	3400-68	1	Potentiometer	

TL1622MK-COMBO Service Manual

**1622MK-COMBO REPLACEMENT PARTS LIST
SEALER PORTION**

Part #	Qty	Description	Price
3400-01	1	Arm Casting – Long	
3400-20	1	Arm Casting – Short	
3440-72	1	Band Ribbon	
3400-96	2	Bearing – Discharge Conveyor	
3440-10	4	Bearing – Discharge Conveyor Stabilizer	
3440-40	1	Belt – Discharge Conveyor	
3440-41	2	Bolts – Short Arm Casting Mounting	
3400-95	1	Bracket – Actuator	
3440-01	1	Bracket – Arm Return Cylinder	
3440-68	1	Bracket – Seal Head Adjustment	
3440-42	2	Bracket – Transition Roller Mounting	
1524-17	1	Bridge Rectifier	
3500-02	1	Capacitor – 3 MF 400 VAC	
3400-03	4	Casters	
3400-04	2	Chain Master Link	
3400-05	1.5	Chain – Riveted (per ft.) Conveyor Motor	
3440-43	1	Chain – Riveted (4 ft) -- Discharge Conveyor Adjustment	
1521-49	1	Compensator Block Insulator – Fiber Washer	
3440-81	2	Compensator Block – Stainless Steel	
3440-44	1	Compensator Screw	
3440-75	1	Compensator Shaft – Front	
3440-76	1	Compensator Shaft – Side	
3440-77	1	Compensator Shaft Spring	
3400-09	1	Conduit (per ft.)	
3400-11	1	Conduit Connector – Straight – 1/2"	
3400-12	2	Contacto – 3 pole – 35 AMP	
3400-14	1	Conveyor Adjusting Bracket	
3440-66	1	Corner Block	
3440-02	1	Cylinder – Head Return	
3440-47	4	Discharge Conveyor – 8" Threaded Adjustment Bolts	
3440-86	1	Discharge Conveyor – Nylon Take-up Block	
3400-18	1	Drive Shaft	
3400-19	1	Film Clamp – Side Stainless Steel	

TL1622MK-COMBO Service Manual

Replacement Parts List – Sealer

Part #	Qty	Description	Price
3400-20	1	Film Clamp – Front Stainless Steel	
3440-48	2	Film Rack Guide Bolts	
3400-21	1	Film Rack with Rollers – Complete	
3440-49	2	Film Rack Roller – Shaft	
3400-22	4	Film Rack Roller Bearings – Large	
3400-23	4	Film Rack Bolts – 7mm x 1”	
3400-24	2	Film Rack Roller	
3400-25	2	Film Rack Guide Bolt Sleeve	
3400-26	1	Film Rack Guide Knob	
3440-50	1	Film Unwind Tension Plate	
3440-51	1	Film Unwind Tension Adjust Knob	
3400-27	1	Fuse – 2 AMP – Conveyor	
3400-28	1	Fuse – 15 AMP	
3400-30	1	Fuse 3 AMP	
3400-31	1	Fuse Holder	
3440-03	1	Guard – Discharge Conveyor Motor	
3440-76	1	Handle – Adjust L’Sealer	
3440-52	1	Handle – Front Seal Bar	
3400-32	1	Handle – Crank for Conveyor	
3400-34	1	Idler Roller Assembly	
3440-69	2	Insulation Sleeve	
3400-35	2	Knob for Potentiometer	
3440-37	1	Knob for Conveyor Crank Handle	
3440-80	1	Knob – Lock L’Sealer Frame	
3440-82	2	Linen Bearings	
3400-40	2	Magnets	
3440-53	4	Magnets– Lower Mounting Bolts	
3400-41	2	Magnet – Upper	
3400-43	2	Magnet Holder – Lower	
3400-45	1	Main Power Switch	
3400-46	1	Main Power Switch Plate	
3440-54	1	Micro Switch Activation Bolt	
3400-47	1	Micro Switch – Safety Override, Pulse, Conveyor	
3440-55	1	Motor – Discharge Conveyor	
3440-56	2	Mounting Bracket – Transition Rollers	

TL1622MK-COMBO Service Manual

Replacement Parts List – Sealer

Part #	Qty	Description	Price
3400-48	2	Pillow Block Bearing	
3400-49	1	Pin Perforator Assembly Complete with Shaft	
3440-04	1	Pin Perforator Base – Adjustment Knob	
3400-36	1	Pin Perforator Safety Cover Adjustment Knob	
3440-59	1	Pin Perforator Safety Cover	
3400-51	1	Pin Perforator Shaft	
3400-52	1	Pin Perforator Wheel – 5/8" I.D.	
3440-11	1	Pin Perforator Base – Nylon	
3400-54	1	Product Separator Tray	
3400-56	1	Relay – Compensator – 24 Volt	
3400-57	1	Relay – Conveyor – 220 Volt	
3400-58	2	Relay Base	
3440-60	2	Rollers – Transition	
3440-05	1	Roller – Discharge Belt – Idler and Drive	
3440-62	1	Screw-wing (Product Loading Tray)	
3440-73	1	Seal Bar – Upper Front – Complete	
3440-74	1	Seal Bar – Upper Side – Complete	
3440-63	4	Seal Pad – Lower, Mounting Bolts	
3400-60	1	Seal Pad – Lower – Front Mounting Bracket	
3400-61	1	Seal Pad – Lower – Side Mounting Bracket	
3440-06	2	Screw – Guide with Insulator	
3450-15	1	Seal Pad Sponge Rubber – Side	
3450-20	1	Seal Pad Sponge Rubber – Front	
3400-33	1	Shaft – Seal Head	
3440-07	4	Shoulder Bolt – Film Clamps	
3400-68	2	Speed Potentiometer (Vr1 & Vr2)	
3440-22	1	Sponge – Handle	
3440-08	4	Spring – Film Clamp	
3440-67	2	Spacer – Film Clamp	
3400-69	1	Sprocket – Conveyor Drive Shaft	
3400-71	1	Sprocket – Conveyor Motor	
3400-72	4	Sprocket – Conveyor Adjustment Up/Down	
1350-08	1	Teflon Tape – 1/2" x 10 yds x 10 Mill 16"	
1350-14	1	Teflon Tape – 3/4" x 10 yds x 10 Mill 16"	
3440-64	1	Teflon Tape – 1/2" x 10 yds x 10 Mill 22"	

TL1622MK-COMBO Service Manual

Replacement Parts List – Sealer

Part #	Qty	Description	Price
3440-65	1	Teflon Tape – ¾" x 10 yds x 10 Mill 22"	
3400-73	1	Temperature Adjusting Bracket	
1521-09	1	Temperature Adjustment Screw Assembly	
3400-74	1	Terminal Strip – 12 Lug	
3400-76	1	Timer – Conveyor	
3400-77	1	Timer – Seal	
1524-27	1	Transformer – Stepdown 200 Volt to 24 Volt T1	
3400-85	1	Transformer – Pulse 220 Volt T2	
3440-70	1	Transite Channel - Front	
3340-71	1	Transite Channel - Side	
3440-09	4	Washer Stainless Steel – Film Clamp	

TL1622MK-COMBO Service Manual

Replacement Parts List – Sealer

Spare Parts List

Item #	Part #	Description	Qty.	Price
1	3440-72	Band Ribbon	2	
2	3500-05	Chain – Master Link	2	
3	3500-14	Fuse - .5A	5	
4	3400-27	Fuse – 2 AMP	3	
5	3400-30	Fuse – 3 AMP	2	
6	3500-15	Fuse – 10A	2	
7	3400-28	Fuse – 15 AMP	3	
8	3500-70	Lubricant – Chain	1	
9	3500-24	Roller 16" Covered	5	
10	3450-15	Seal Pad Rubber – Front	1	
11	3450-20	Seal Pad Rubber – Side	1	
12	1350-08	½" x 10 mill x 10 yd. Teflon tape	1 RL	
13	1350-14	¾" x 10 mill x 10 yd. Teflon tape	1 RL	
14	3440-70	Transite Channel – Front	1	
15	3440-71	Transite Channel – Side	1	
Total Cost				\$270.00

03/14/00